

---

NONDESTRUCTIVE TESTING

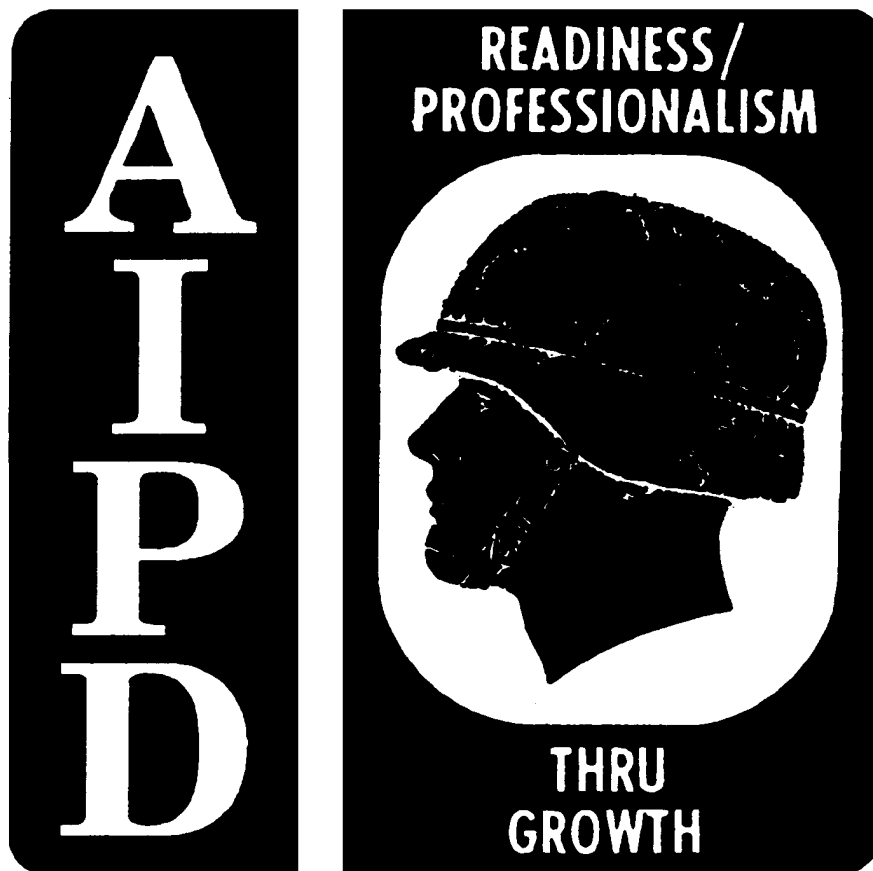

---

THE ARMY INSTITUTE FOR PROFESSIONAL DEVELOPMENT  
ARMY CORRESPONDENCE COURSE PROGRAM

---

# NONDESTRUCTIVE TESTING

Subcourse Number AL 0917

EDITION A

United States Army Aviation Logistics School

Fort Eustis, Virginia 23604

2 Credit Hours

Edition Date: October 1993

## SUBCOURSE OVERVIEW

This subcourse is designed to familiarize you with nondestructive testing.

There are no prerequisites for this subcourse.

This subcourse reflects the doctrine which was current at the time it was prepared. In your own work situation, always refer to the latest official publications.

Unless otherwise stated, the masculine gender of singular pronouns is used to refer to both men and women.

### TERMINAL LEARNING OBJECTIVE

- ACTION:** You will develop a knowledge of the fundamentals and principles of nondestructive testing.
- CONDITION:** You will have the instructional material presented in this lesson.
- STANDARD:** To demonstrate a knowledge of the material presented in this lesson, you must achieve a minimum of 70 percent on the subcourse examination.

## TABLE OF CONTENTS

	Page
Subcourse Overview .....	i
Administration Instructions .....	iii
Grading and Certificate Instructions .....	iii
Lesson 1: Fluorescent Penetrant Testing .....	1-1
Practice Exercise .....	1-29
Answer Key and Feedback .....	1-32
Lesson 2: Magnetic Particle Testing .....	2-1
Practice Exercise .....	2-21
Answer Key and Feedback .....	2-24
Appendix A: References .....	A-1
Appendix B: Glossary .....	B-1
Examination .....	E-1
Student Inquiry.....	

## GRADING AND CERTIFICATION INSTRUCTIONS

**Examination:** This subcourse has a multiple-choice test covering the material contained in the two lessons. After studying the lessons and working through the practice exercises, complete the examination. A score of 70 percent or above is passing. Two credit hours will be awarded for successful completion of this examination.

## LESSON 1

### FLUORESCENT PENETRANT TESTING

#### OVERVIEW

##### LESSON DESCRIPTION:

In this lesson you will be introduced to the fundamentals of fluorescent penetrant inspection.

##### TERMINAL LEARNING OBJECTIVE:

**ACTION:** Develop a knowledge of the fundamentals of fluorescent penetrant inspection.

**CONDITIONS:** You will be given instructions in this lesson covering fluorescent penetrant inspection.

**STANDARD:** You will demonstrate a knowledge of the material presented in this lesson by correctly completing the practical exercise.

**REFERENCE:** The material contained in this lesson was derived from TM 55-1500-335-23, MIL-STD 410, and MIL-STD-6866.

#### INTRODUCTION

NDI methods in the hands of a trained and experienced technician are capable of detecting flaws or defects with a high degree of accuracy and reliability. It is important that maintenance personnel be fully knowledgeable of the capabilities of each method, but it is equally important that they recognize the limitations of the methods. NDI is not a panacea for inspection ills. It is merely a means of extending the human senses in performing an inspection function.

1. Background.

a. Liquid penetrant inspection is one of the oldest of modern nondestructive inspection methods. It originated in the railroad maintenance shops in the late 1800s. Parts to be inspected would be immersed in used machine oil. After a suitable immersion time, the parts were withdrawn from the oil and the excess surface oil wiped off with rags or wadding. The part surfaces would then be coated with powdered chalk or a mixture of chalk suspended in alcohol (whiting). Oil trapped in cracks or flaws would bleed-out causing a noticeable stain in the white chalk coating.

b. The oil-and-whiting method was replaced by magnetic particle inspection on steel and ferrous parts in 1930. However, industries using nonferro-magnetic metals, especially aircraft manufacturers, needed a more reliable and sophisticated tool than discolored machine oil and chalk. In 1941, fluorescent dye materials were added to a highly penetrating oil to make a penetrant material.

2. Capabilities of Penetrant Inspection. Penetrant inspection is a simple, inexpensive, and reliable nondestructive inspection method for detecting discontinuities which are open to the surface of the item to be inspected. It can be used on metals and other nonporous materials that are not attacked by penetrant materials. With the proper technique, it will detect a wide variety of discontinuities ranging in size from those readily visible down to the microscopic level, as long as the discontinuities are open to the surface and are sufficiently free of foreign material.

3. Basic Penetrant Process. The basic fundamentals of the penetrant process have not changed from the oil-and-whiting days. In Step 1, a penetrating liquid containing dyes is applied to the surface of a clean part to be inspected. Cleaning is not part of the penetrant process but is emphasized because of its effect on the inspection results. Contaminates, soils or moisture, either inside the flaw or on the part surface at the flaw opening, can reduce the effectiveness of the inspection. The penetrant is allowed to remain on the part surface for a period of time to permit it to enter and fill any openings or discontinuities. After a suitable dwell period, the penetrant is removed from the part surface, as in Step 2. Care must be exercised to prevent removal of penetrant contained in discontinuities. A material called developer is then applied (Step 3). The developer aids in drawing any trapped penetrant from discontinuities and improves the visibility of indications (Figure 1-1).

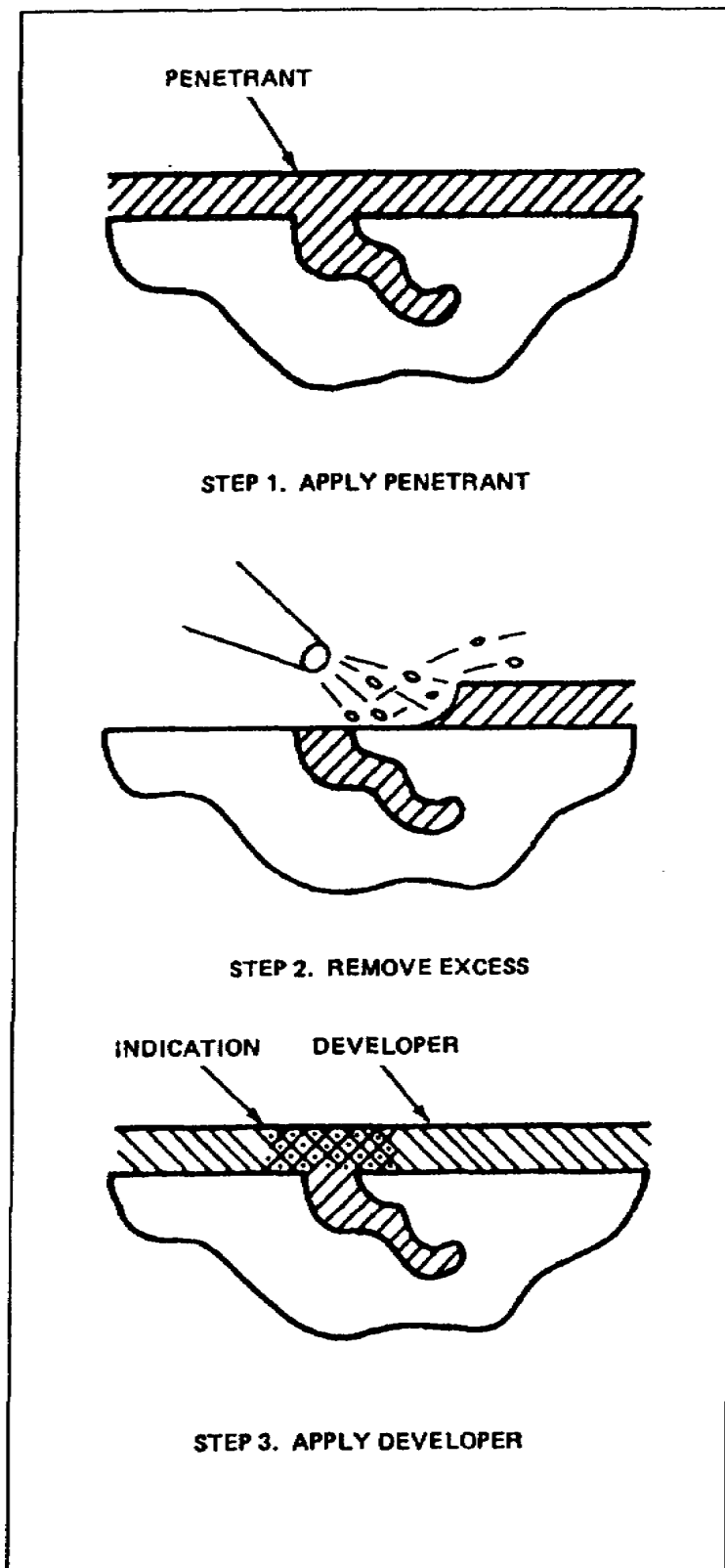

Figure 1-1. Basic penetrant process

4. Personnel Requirements. The apparent simplicity of the penetrant inspection is deceptive. Very slight variations in performing the inspection process can invalidate the inspection by failing to indicate serious flaws. It is essential that personnel performing penetrant inspection be trained and experienced in the penetrant process. All individuals who apply penetrant materials or examine components for penetrant indications shall be qualified as specified in MIL-STD-410.

5. Equipment Requirements. The equipment used in the penetrant inspection process varies from spray or aerosol cans to complex automated systems.

a. Portable Equipment. Penetrant inspection can be performed on installed parts. Penetrant materials are available in aerosol spray cans and in small containers. Portable penetrant applications are limited to localized area or spot inspections rather than entire part surfaces (e.g., landing wheels)(Figure 1-2).

b. Small Parts Inspection Unit. There are inspection units designed for processing small parts. In use the parts are loaded into wire baskets which are then batch processed through each of the stations. The wash station contains a water-driven, rotary table with spray jets to supplement the hand-held spray wand (Figure 1-3).

6. Advantages.

a. Liquid penetrant is capable of examining all of the exterior surfaces of objects, even of complex shapes, in one operation.

b. Liquid penetrant inspection is capable of detecting very small discontinuities. It is one of the more sensitive nondestructive inspection methods for detecting surface flaws.

c. Liquid penetrant inspection can be used on a wide variety of materials: ferrous and nonferrous metals and alloys, fired ceramics and cermets, powdered-metal products, glass, and some types of organic materials.

d. Liquid penetrant inspection can be accomplished with relatively inexpensive, nonsophisticated equipment. If the area to be inspected is small, the inspection can be accomplished with portable equipment.

e. Liquid penetrant inspection magnifies the apparent size of discontinuities making the indications more visible.

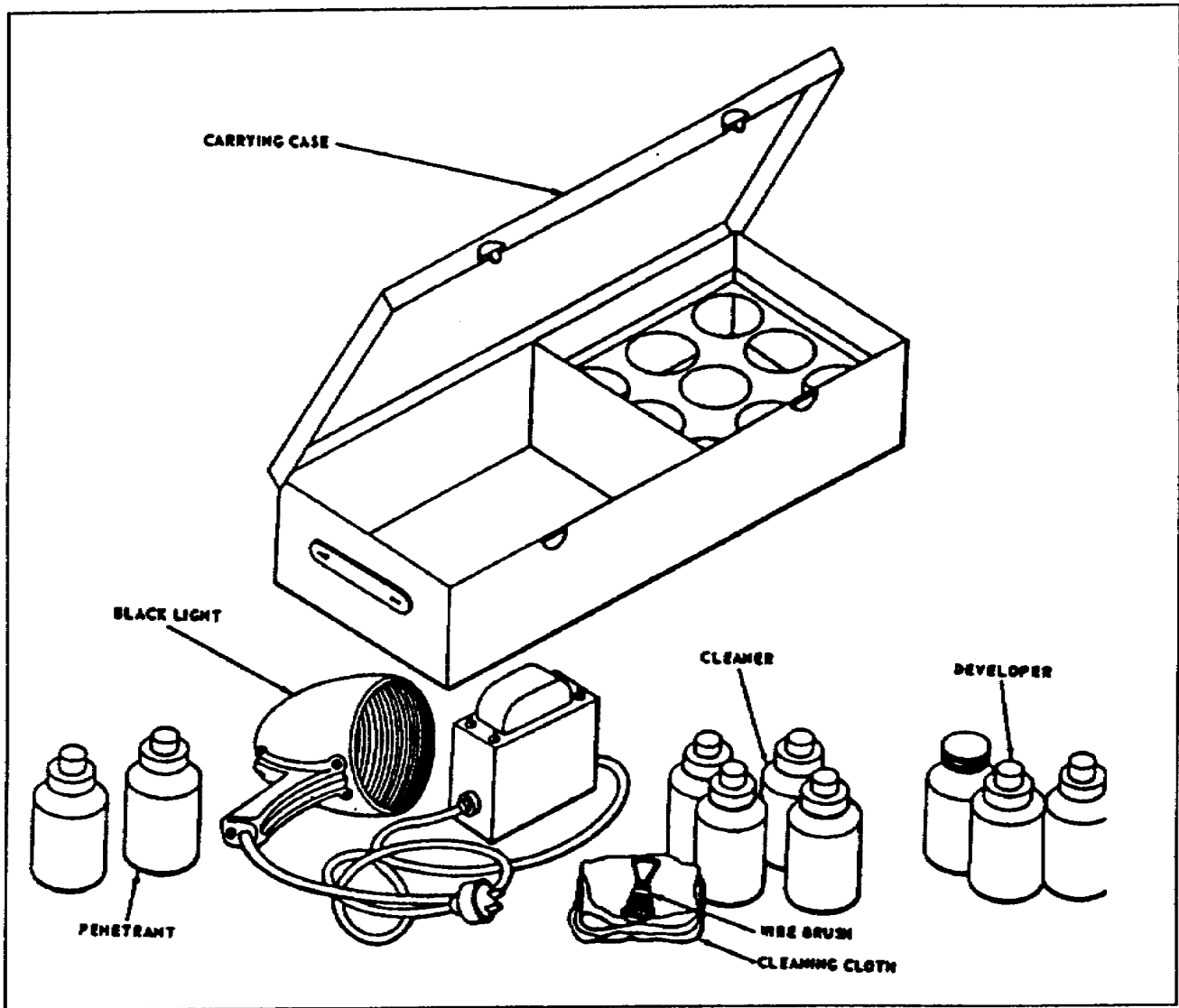

Figure 1-2. Portable equipment

f. Liquid penetrant inspection is readily adapted to volume processing permitting 100 percent inspection.

g. Liquid penetrant inspection may be adjusted to provide various sensitivity levels through the proper choice of materials and processing procedures or techniques.

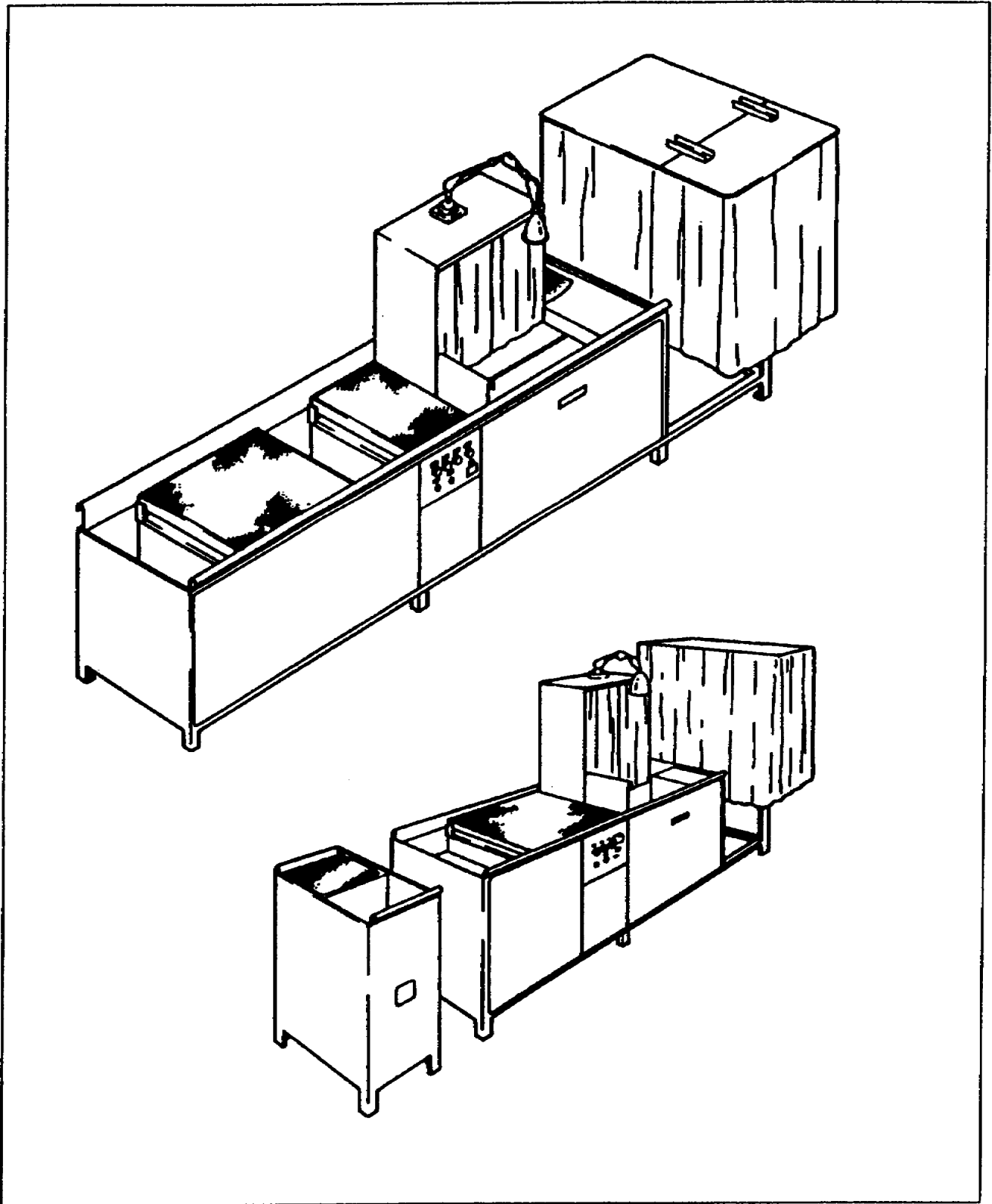

Figure 1-3. Small parts inspection unit

7. Disadvantages.

a. Penetrant inspection depends upon the ability of the penetrating media to enter and fill discontinuities. Penetrant inspection will only reveal discontinuities that are open to the surface of the part being inspected.

b. The surfaces of objects to be inspected must be clean and free of organic or inorganic contaminants which will impede the action of the penetrating media.

c. Penetrants are usually oily materials with strong solvent powers and highly concentrated dyes. They will attack some nonmetallic materials such as rubber and plastics.

d. Penetrants, emulsifiers, and some types of developers all have very good wetting and detergent properties. They can act as solvents for fats and oils. If they are allowed to remain in contact with body surfaces for extended periods, they may cause skin irritation.

e. Most penetrants are combustible but have relatively high flashpoints. They are not considered a serious fire hazard in open tanks. However, when sprayed as a fine mist, they are easy to ignite and open ignition sources must be avoided when spraying is used.

f. Some penetrant materials contain volatile solvents that can be nauseating or narcotic. This is especially true of the vehicles in aerosol or pressure spray cans.

g. Most penetrant materials are oily in nature and, therefore, must not be used on parts, such as assemblies, where they cannot be completely removed and will subsequently come in contact with oxygen, either liquid or gaseous.

8. Types of Penetrant. There are three types of penetrant in general use. Penetrants obtain visibility by dissolving highly colored dyes in the penetrating vehicle or oil. The type of dye materials provides one means of classifying penetrants.

a. Fluorescent Penetrant (Type I). Some chemical compounds have the capability of emitting visible light when exposed to near-ultraviolet or black light (energy with a wavelength of 320 to 400 nanometers). This property is termed fluorescence and the materials are called fluorescent. With the selection of proper fluorescent materials, very small quantities of penetrant will emit highly visible indications when exposed to black light. This is the only type authorized for use on aircraft.

b. Visible Penetrant (Type II). Visible dye or color contrast penetrants contain a red dye stuff dissolved in the penetrating oil. The use of visible penetrant on aircraft and engine parts is PROHIBITED.

c. Visible and fluorescent Penetrant (Dual Mode)(Type III). Dual mode (visible and fluorescent) penetrants contain dye materials that are both reddish in color under white light and fluorescent under black light. However, both the intense, red visible color and the fluorescent properties are compromised compared to the individual visible dye and fluorescent penetrants; the brilliance of color and amount of fluorescent are reduced. The use of dual-mode penetrant on aircraft and engine parts is PROHIBITED.

9. Methods of Removal. Penetrant materials are compounded or formulated for specific removal methods. The removal method provides another means of classifying penetrant materials.

a. Water-Washable Penetrant (Method A). The usual liquid base or vehicle for a penetrant is a petroleum oil which is insoluble or immiscible in water. There are chemical compounds (usually oil-based liquids) that can mix with penetrant oils to form an emulsifiable mixture. An emulsified oil is one that can be removed with a water spray. Water-washable penetrants SHALL NOT be used on aircraft and engine parts.

b. Post-Emulsifiable, Lipophilic (Method B). Penetrants used in the post-emulsifiable, lipophilic method are formulated to optimize their penetrating and visibility characteristics. They do not contain any emulsifying agent and cannot be removed with plain water. Removal is made possible by applying an emulsifier as a separate process step. This converts the excess surface penetrant into an emulsifiable mixture which can be removed with a water spray (Figure 1-4).

c. Solvent Removable (Method C). The term "solvent removable" applies to the process rather than the material since all oil-based penetrants can be removed with solvents. Removal is accomplished through dissolving and dilution (Figure 1-5).

d. Post-Emulsifiable, Hydrophilic (Method D). The post-emulsifiable, hydrophilic method uses penetrants without emulsifier. They are the same as, or similar to, the penetrants used in the lipophilic methods as in the materials and procedures used in the removable process. Hydrophilic removal is accomplished with a water-based solution and detergent, surface action. The hydrophilic method is preferred over the lipophilic method as it provides greater control over the removal process and produces less residual background (Figure 1-6).

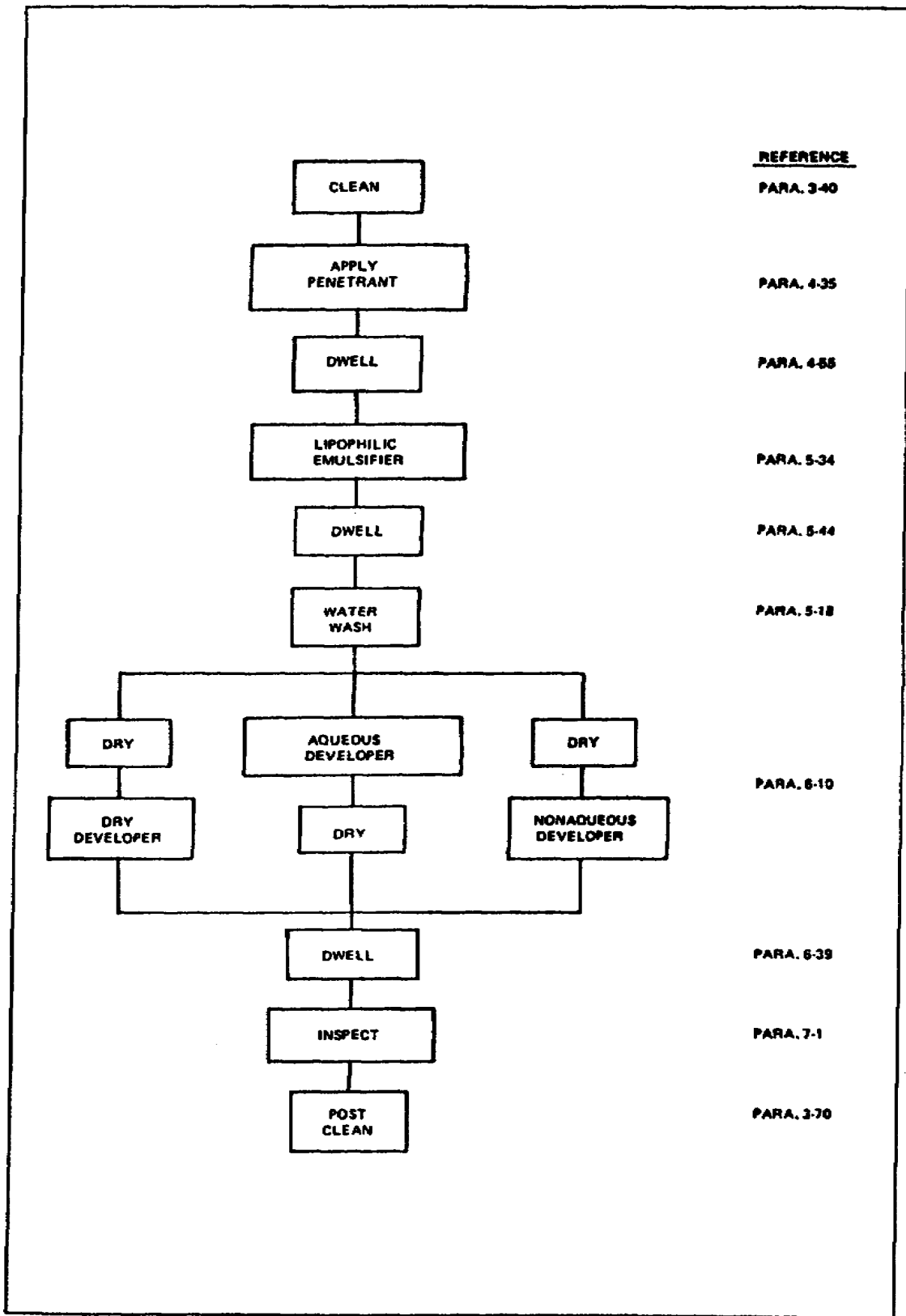

Figure 1-4. Post-emulsifiable, lipophilic (method B)

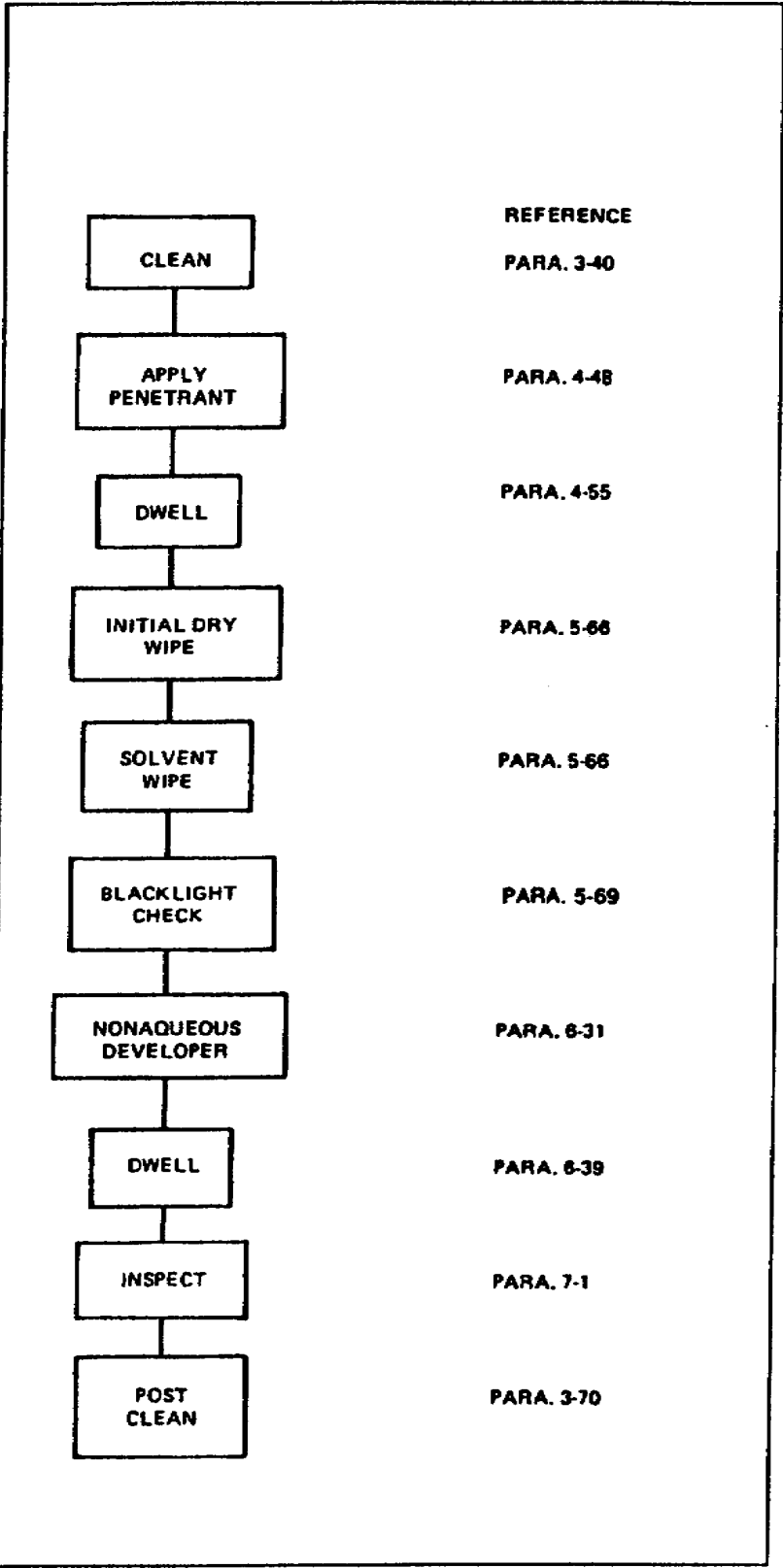

Figure 1-5. Solvent removable (method C)

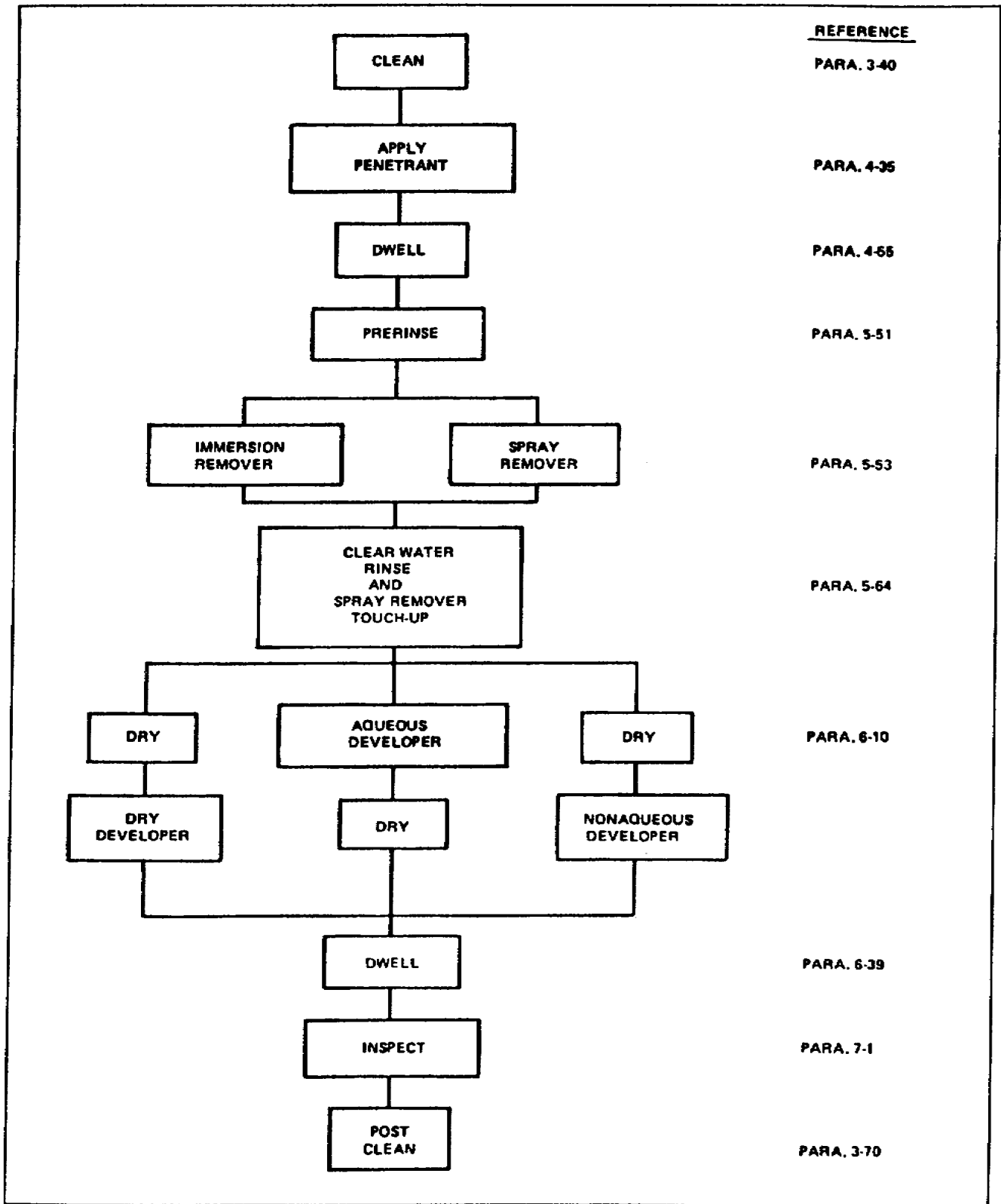

Figure 1-6. Post-emulsifiable, hydrophilic (method D)

10. Sensitivity. The term "sensitivity" when used in conjunction with penetrant systems refers to the ability of detecting small, tight flaws. Sensitivity is a relative factor in that it does not provide a measured numerical result. Sensitivity is determined by applying the penetrant system to a cracked panel, plate, or block and comparing the resulting indications with those from a reference standard.

a. Penetrant systems (penetrant/emulsifier or remover) are classified into four sensitivity levels, as follows:

- (1) Sensitivity Level 1 - Low
- (2) Sensitivity Level 2 - Medium
- (3) Sensitivity Level 3 - High
- (4) Sensitivity Level 4 - Ultrahigh

b. It is not necessary, nor is it always possible, to use the higher sensitivity materials. Large flaws, such as those caused by overstress, can be detected with low sensitivity materials. Small, tight fatigue cracks, such as those occurring on engine rotating parts, require ultrahigh sensitivity materials. The majority of flaws encountered in aircraft maintenance can be detected with medium or high sensitivity penetrant systems.

c. Parts with rough surfaces, such as casting, welds, forged, and overreacted parts, tend to retain some of the penetrant. The use of high or ultrahigh sensitivity penetrants on rough surfaces may produce an excessive residual background that could obscure potential flaws. Penetrant is very easily removed from smooth, polished surfaces. Low or medium sensitivity penetrants may not detect small flaws in smooth, polished surfaces due to the ease of over removal.

11. System Concept. Each penetrant inspection material's manufacture has its own formulation for penetrants; lipophilic emulsifiers and hydrophilic removers are qualified as a system. This system consists of specific materials from the same manufacturer. Mixing of manufacturers or components from the same manufacturer that are not part of the system will not provide for optimum performance. In some cases, this practice will eliminate any chance of detecting defects; therefore, it SHALL NOT be done.

a. Any manufacturer's developer can be used with combined penetrant and lipophilic emulsifier or hydrophilic remover system of another manufacture.

b. Two or more different types of developers or remover/cleaners SHALL NOT be mixed together.

c. Two or more developers and solvent removers of the same type and manufacturer but having different part numbers SHALL NOT be used or mixed together.

12. Cleaning. The proper preparation of parts prior to inspection is critical. Successful detection of discontinuities by penetrant inspection depends upon the ability of the penetrant to enter and exit from the discontinuity. The resulting indication must be readily distinguished from the background. Surface conditions, such as coatings or soil contaminations, can reduce the effectiveness of the inspection by interfering with the entry and exit process or by producing a high residual background.

a. Penetrant inspection is reliable only when the parts to be inspected are free of contaminants. Foreign material, either on the surface or within the discontinuity, can produce erroneous results. Any interfering conditions must be removed by proper cleaning or surface treatment prior to penetrant application.

b. Improper cleaning methods can cause severe damage or degradation of parts. The use of raw steam for cleaning aircraft surfaces is PROHIBITED.

13. Effects of Water or Moisture. Water or moisture on the part surface or in the discontinuity seriously interferes with the mechanism of penetration, impeding the entry and exit of penetrant from the discontinuity. It is essential that water be removed not only from the part surface but also from the inside of any discontinuities that may be present.

14. Effects of Cleaning Process Residues. The chemicals used for cleaning solutions may contain strong alkalies and acids. If not completely removed from the part surface before penetrant inspection, they can interfere with the penetrant process in several ways. They can impede surface wetting, preventing the penetrant from evenly coating the inspection area. They also interfere with the mechanism causing the penetrant to enter and exit discontinuities. Strong alkalies and acids can decompose or degrade dyes and other chemicals in the penetrant, resulting in weak or faint indications. Chromate residues absorb black light, leaving less energy to excite the fluorescent dyes in the penetrant.

15. Removal of Cleaning Process Residues. Cleaning process residues are removed by rinsing with fresh water. The use of warm water and agitation followed by repeated immersions in fresh water assist in complete removal. In some cases, residues of strong alkalies and acids are subject to a rinse with a weak neutralizing solution followed by fresh water rinses.

16. Effects of Mechanical Working. Mechanical working removes soils and contaminates by physical action. This physical action also removes or deforms the part surface. Even a small amount of deformation, such as that caused by fine sanding or vapor blasting, will reduce the surface opening of small discontinuities, resulting in a decrease in the effectiveness in the penetrant inspection process. Chemical etching should be accomplished when penetrant inspection is performed after a less severe mechanical working process.

17. Severe Mechanical Working. Severe mechanical working processes, such as metal removal, shot peening, or grit blasting, can seal or close the surface openings of large discontinuities which prevents the formation of penetrant indications. Penetrant inspection SHALL be accomplished prior to mechanical work processes, such as machining, shot peening, grit blasting, plastic media bead blasting, or coarse sanding, which severely displace surface metal. If it is not feasible to perform penetrant inspection prior to these processes, then another inspection method should be considered (Figure 1-7).

18. Temperature Limitations. The operating range for conventional penetrants is 400 to 1200 Fahrenheit (part temperature).

19. Penetrant Dwell. Penetrant dwell is the total length of time from the initial application of penetrant until its removal. This includes immersion, soak, and drain times. The purpose of dwell is to allow the penetrant to seep into and fill any surface openings.

20. Dwell Modes. There are two basic penetrant dwell modes--

a. Immersion Dwell is where the part remains submerged in a tank of liquid penetrant for the entire period.

b. Drain Dwell is where the part is first covered with penetrant by spraying, brushing, or immersing. Once coated, the part is placed on a rack or rest and allowed to drain during the dwell period. The drain dwell mode SHALL be used unless the inspection instruction specifies immersion dwell.

21. Minimum Penetrant Dwell Times. The number of factors influencing the entry of penetrant into a discontinuity complicates setting uniform minimum penetrant dwell times. Most dwell times are based on past experience with similar parts, materials, and potential flaws. The minimum dwell time for service-induced defects SHALL NOT be less than 30 minutes. There is one exception to this requirement. When stress corrosion is suspected, the minimum dwell time SHALL NOT be less than 240 minutes. These established minimum dwell times are based on parts having a temperature of 60°-100f Fahrenheit.

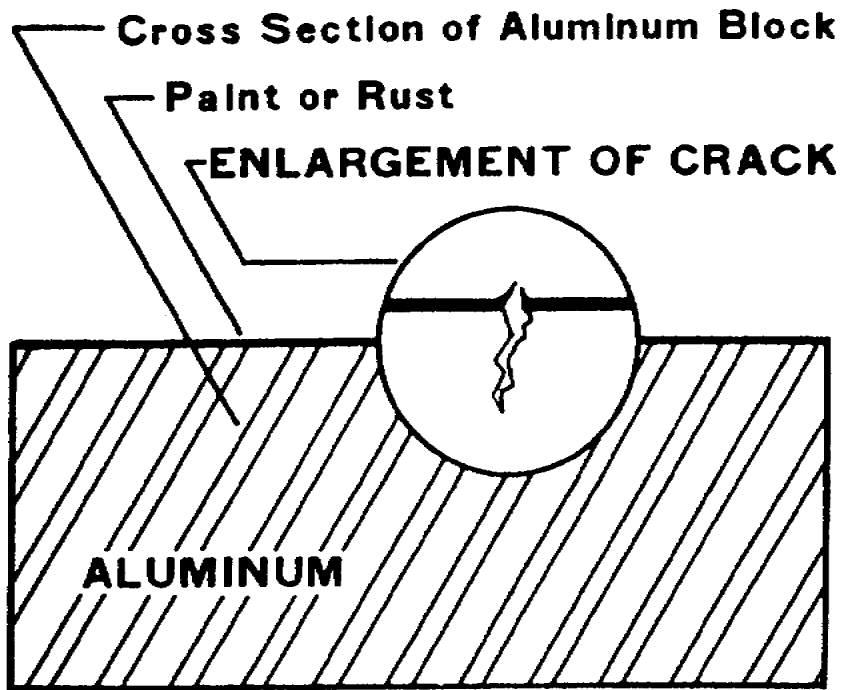

**A**

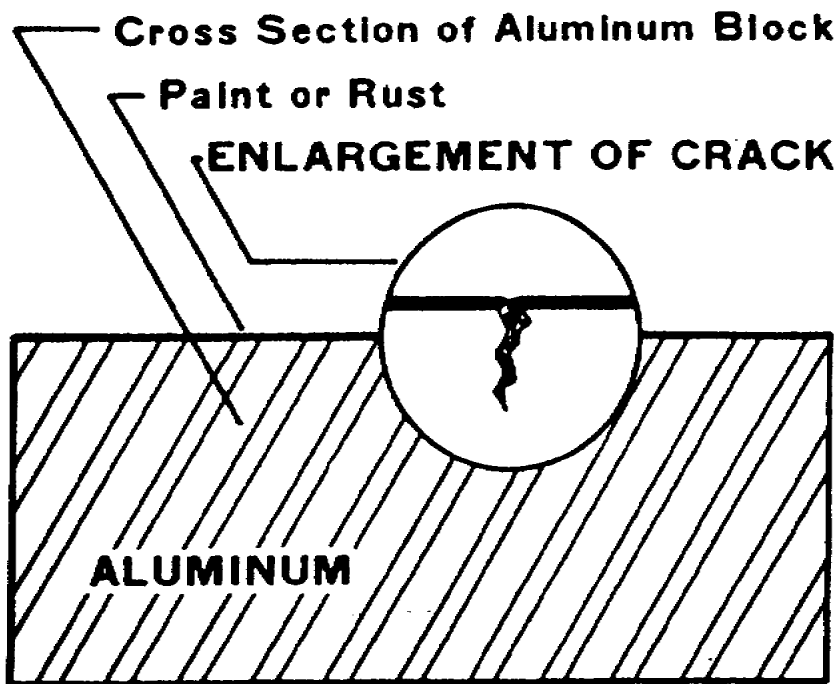

**WRONG**

**B**

Figure 1-7. Severe mechanical working

a. When part temperatures are 100°-120° Fahrenheit, the dwell time may be reduced by one half.

b. When the part temperatures are between 600-400 Fahrenheit, the minimum dwell time SHALL be doubled.

c. Penetrant inspection SHALL NOT be performed with part temperatures below 400 Fahrenheit or above 1200 Fahrenheit.

22. Penetrant Removal. After the penetrant has been applied and has filled any open discontinuities, the excess penetrant on the surface must be removed. This is a critical step in the inspection process. Improper removal can lead to misinterpretation and erroneous results.

23. Lipophilic and Hydrophilic. The words "lipophilic" and "hydrophilic," like many other chemical and medical terms, have their basis in Greek work elements. "Lipo" comes from the Greek word for oil or fat. "Hydro" is from the Greek word for water. "Philic" means a fondness or affinity for, borrowed from the Greek word "philos" for loving. Thus, lipophilic is an oil-based solution. In this lesson, the word "emulsifier" will be used when referring to lipophilic material, and the word "remover" will be used when discussing hydrophilic material. This is a practice generally used by industry.

24. Lipophilic Process, Method B.

a. Application of Emulsifier. Lipophilic emulsifier is usually applied by dipping or immersing the part in a tank of emulsifier. Application by spraying or flowing of emulsifier is not recommended. The problem with spraying is the difficulty of applying enough emulsifier without mechanical force of the spray scrubbing the penetrant layer. Emulsifier SHALL NOT be applied by brushing or wiping. Brushing or wiping produces an uncontrolled and uneven mixing action.

b. Emulsifier Drain. When the part surface has been coated with emulsifier, the part SHALL be removed from the liquid and allowed to drain. The part SHALL NOT remain in the emulsifier during the drain period.

c. Emulsifier Dwell. After emulsifier has been applied, a period of time is allowed for diffusion. This is the emulsifier dwell time and is one of the most critical factors in the lipophilic process. The objective is to stop the diffusion when the emulsifier has just reached the part surface and before it diffuses into any penetrant entrapped in a discontinuity (Figure 1-8).

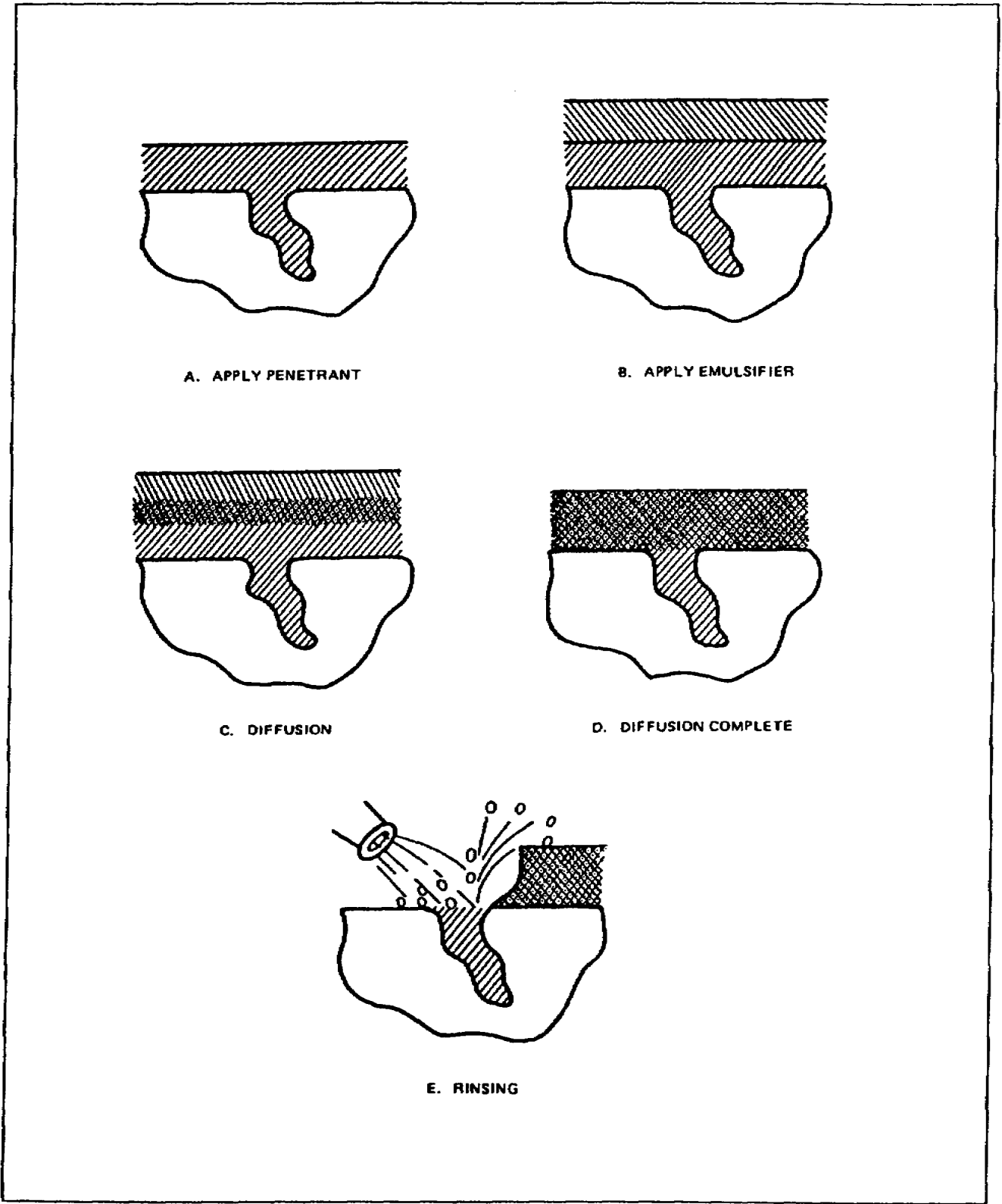

Figure 1-8. Emulsifier dwell

d. Emulsifier Dwell Time. Optimum emulsifier dwell time must be determined on each part by experiment. At the extreme, dwell times may range from 10 seconds to 5 minutes; however, typical dwell times are less than 1 minute. Under no circumstances shall the emulsifier dwell time exceed 5 minutes. The lipophilic emulsion step does not tolerate deviation from the optimum dwell time. A relatively short over-emulsification time of 10 seconds on a 1 minute dwell period can result in failure to indicate small flaws.

e. Water Rinsing Emulsifier. When diffusion of the emulsifier has reached the desired end point, further diffusion is stopped by spraying with water.

f. Over or Under Emulsification. The part SHALL be completely reprocessed if, during or after the rinse step, it is suspected that a too short (under emulsification) or too long (over emulsification) dwell time has occurred. Correction of dwell time cannot be made by immersing in penetrant or emulsifier. The part must be cleaned to remove all residual penetrant and reprocessed through the entire process.

25. Hydrophilic Remover Process, Method D. The objective in both the lipophilic and the hydrophilic methods is the removal of excess surface penetrant without removing any of the penetrants entrapped in discontinuities. However, the hydrophilic method is completely different from the lipophilic method. The differences are in the materials, mechanism or mode of action, and procedures used (the removal of excess surface penetrant using immersion or spray techniques).

a. Mechanism or Mode of Action. Hydrophilic removers consist of water soluble chemicals, usually nonionic surface active agents called surfactants. The surface active agent in the remover displaces a small quantity of penetrant from the surface and prevents it from recombining with the remaining penetrant layer. Unlike lipophilic emulsifier, hydrophilic remover is immiscible in penetrant and diffusion does not occur. All of the removal action takes place at the exposed surface, and penetrant just below the surface is not involved until it becomes exposed (Figure 1-9).

b. Prerinse. The part is subjected to a plain water spray following the penetrant dwell when using the hydrophilic method. The mechanical action of the water spray removes over 80 percent of the excess surface penetrant, leaving only a very thin layer on the part. This prerinse step cannot be used in the lipophilic process as the oil-based emulsifier does not tolerate water.

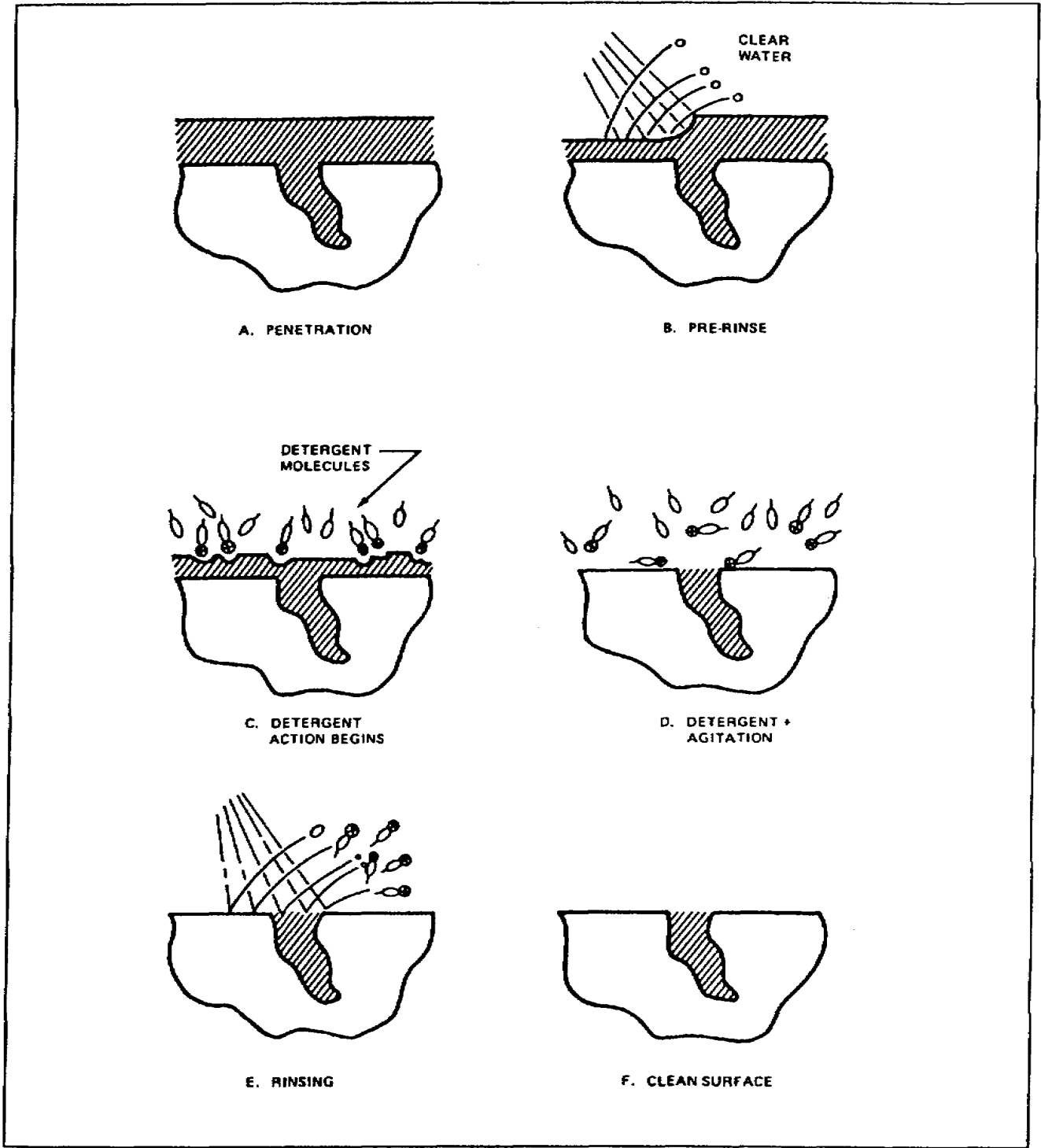

Figure 1-9. Hydrophilic remover process

c. Application of Remover. The removal of excess surface penetrant using hydrophilic removers can be accomplished through the use of either immersion or spray techniques.

d. Remover Dwell Time. Time will vary between 30 seconds and 2 minutes. The maximum time of 2 minutes is seldom necessary except on very rough surfaces or when remover is depleted.

e. Water Rinse. Following the penetrant removal step, the part SHALL be subjected to a plain water rinse or wash. The cycle SHALL be plain water spray of 30 to 60 seconds duration, at a line pressure of 10 to 35 psig, with the water at ambient temperature of 550-100° Fahrenheit. Rinsing of fluorescent penetrants SHALL be accomplished under a black light. One of the advantages of the hydrophilic technique is the ability to touchup removal on local areas after the initial application of the water rinse. After touch-up, the part SHALL be fresh water rinsed.

26. Comparison of Lipophilic and Hydrophilic. A major advantage of hydrophilic removers is the increased process tolerance, i.e., removal time is not as critical as emulsification dwell. Over-removal times of 1 or 2 minutes have little effect on penetrant entrapped in a discontinuity, while over-emulsification times as short as 10 or 15 seconds can seriously degrade a flaw indication. Another advantage of hydrophilic remover is its relative insensitivity to removal of penetrant entrapped in a relative discontinuity. It permits complete removal of fluorescent background in most cases. In contrast, when using lipophilic emulsifier on slightly rough surfaces, it is desirable to leave a faint residual background when maximum sensitivity is required. The reduction of background fluorescent with the hydrophilic technique improves the contrast, making faint indications easier to see. The hydrophilic method also allows spot or touch-up removal on local areas during the final clear water rinse. This cannot be done with the lipophilic method since the oil-based emulsifier will not tolerate water.

27. Solvent Removable (Method C).

a. General. All oil-based penetrants are soluble in a large number of organic liquids. However, post-emulsified penetrants are most frequently used in Method C. The solvents are usually volatile mixtures of either chlorinated hydrocarbons or aliphatic petroleums. They are in closed containers, i.e., aerosol or pressure can, because of their high evaporation rate. Removal is accomplished through dissolving and dilution.

b. Application Procedures. Following the penetrant dwell period, the surface SHALL be wiped with a clean, dry rag or paper

towel to remove the major portion of surface penetrant. The proper procedure is to make a single pass and then fold the rag or towel over to provide a fresh surface for each succeeding wipe. When the surface penetrant has been reduced to a minimum with dry rags or towels, any residual penetrant is removed with a fresh rag or towel moistened with solvent. The amount of solvent applied to the rag or towel is critical. The cloth or towel should only be moistened.

(1) The cloth SHALL NOT be saturated either by immersion in liquid solvent or sprayed-on solvent. A black light SHALL be used to examine the part surface during the intermediate and final wiping stages. The surface of the rag SHALL also be examined with the black light after the final solvent wipe.

(2) The solvent-cleaner SHALL NOT be sprayed directly on the inspection area to remove excess penetrant.

## 28. Developers.

a. Functions. The basic function of all developers is to improve the visibility of the entrapped penetrant indication. The improvement in visibility is achieved through a number of mechanisms which include the following (Figure 1-10):

(1) Assist in extracting the entrapped penetrant from discontinuities.

(2) Increase in the surface layer thickness of exuded penetrant, thereby increasing the apparent brightness of the indication.

(3) Spread or disperse the exuded penetrant laterally on the surface, thus increasing the apparent size of the indication.

(4) Improve the contrast between the indication and the background.

b. Drying. After removal of excess surface penetrant, the parts must be dried before applying dry developer. When aqueous developers are used, the drying is done after application of the wet developer. Drying can be accomplished in a number of ways--

(1) Ambient or Room Air. Parts can be dried by allowing the parts to set in still air. The length of time required for this method depends upon the humidity of the air and is usually too long to be used for drying wet developer.

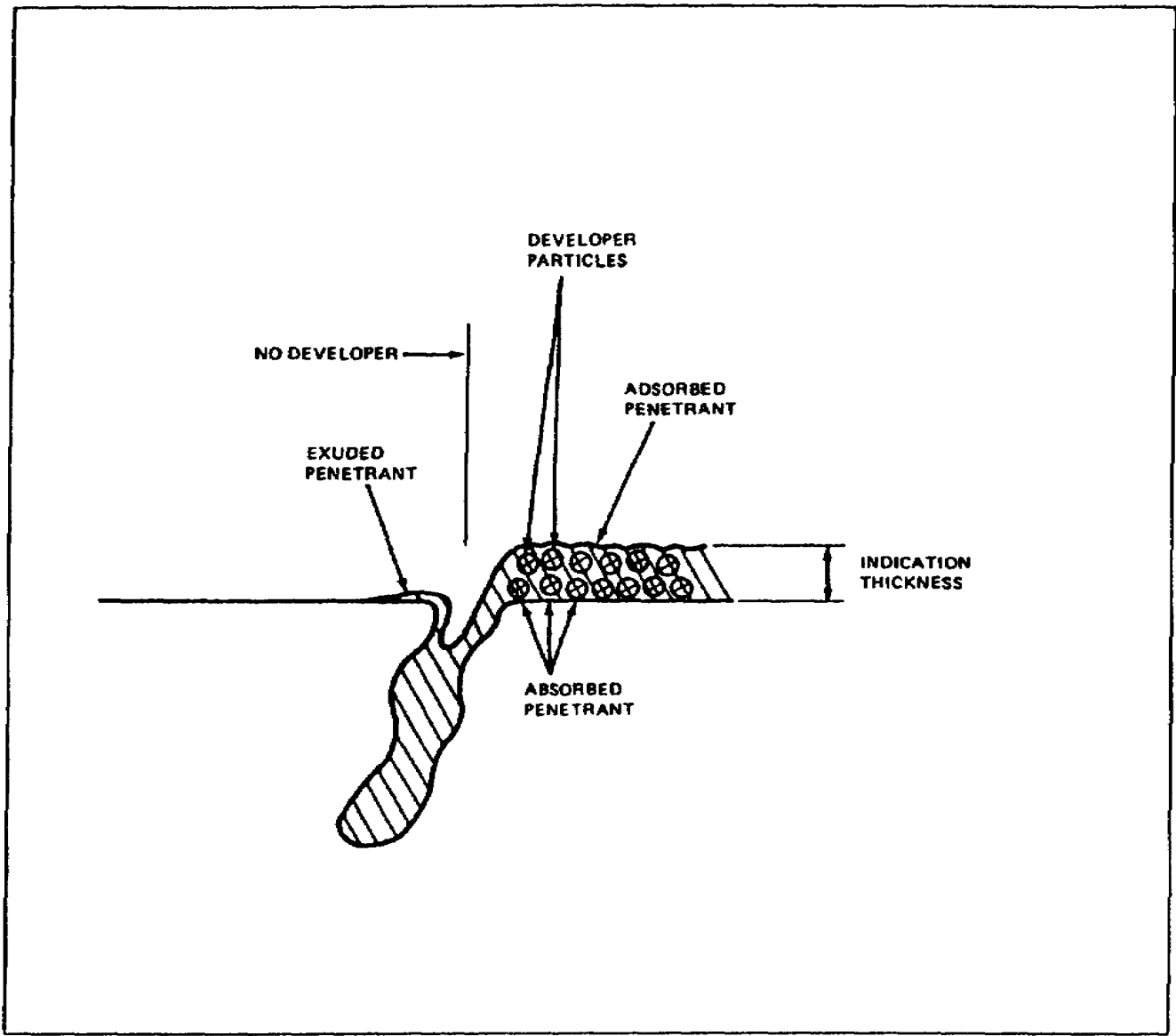

Figure 1-10. Effects of a developer

(2) Warm Air Blowers. Warm air blowers are often used on large parts which cannot be oven dried. The method may not properly dry wet developers.

(3) Recirculating Air Ovens. The most frequently used method of drying parts is with a recirculating hot air oven. It provides a rapid means of properly drying parts and wet developer, is adaptable to production, and permits control of the temperature.

c. Forms of Developers. There are four forms of developers in general use. The four forms are--

(1) Dry Powder. Dry developers can be used with any type of fluorescent penetrant. They are loosely held on the part surface by adhesion. They do not adhere well on smooth, polished, or mirror surfaces and require some penetrant at the surface to hold them in place.

(2) Water Suspended (Wet-Aqueous). Water-suspended developers consist of inert particles in a water suspension. The particles are insoluble in water and when dry are highly adsorptive. Water-suspended developers CANNOT be used on aircraft and engine parts.

(3) Water Soluble. Water soluble developers contain developer particles, wetting agents, and corrosion inhibitors. They differ from wet suspended developer since the particles dissolve in water to form a clear solution.

(4) Nonaqueous Solvent Suspended. Nonaqueous solvent-suspended developers are supplied in ready-to-use condition and contain particles of developer suspended in a mixture of volatile solvents. Solvent developers are the most sensitive form of developers due to the solvent action contributing to the adsorption and absorption mechanisms. Nonaqueous wet developers are always applied by spraying.

d. Developer Dwell. Extraction of the penetrant entrapped in a flaw is a function of time and volume of available penetrant. Time must be allowed for the developer to assist in drawing some of the entrapped penetrant from the flaw and spreading it on the part surface to form the indication. The length of developing time varies widely with a number of influencing factors. The development time SHALL be at least one half of the penetrant dwell time and SHALL NOT start until part is completely free of moisture.

## 29. Lighting and Facilities.

a. Black Light. Black light has the smallest band width of the ultraviolet range and is just below visible wavelength light. The eye is not too responsive to black light, especially if visible light is present. However, with reduced visible light, the sensitivity of the eye increases and with large amounts of black light, the longer wavelengths may be visible.

b. Low-Pressure Fluorescent Bulbs. Low-pressure fluorescent bulbs are similar to standard fluorescent tubes. However, instead of an inert gas, the tube contains metallic mercury. Fluorescent black lights SHALL NOT be used for detecting fluorescent indications.

c. High-Pressure Mercury-Vapor Bulbs. High-pressure, mercury-vapor bulbs are the most common sources for black light. They are preferred for fluorescent penetrant inspection because they have an acceptable output at a reasonable distance from the bulb. They can be focused to increase their intensity on a localized area. They are available in a wide range of sizes from a 2-watt pencil-type to a 400-watt floodlight. The smaller sizes, less than 100 watt, SHALL NOT be used for penetrant inspection. Black lights SHALL be energized for 15 minutes before inspection is performed. The most frequently used size is the 100-watt bulb which is mounted in a variety of fixtures or housings and is fairly portable (Figure 1-11).

d. Black Light Intensity Requirement. The adequacy of a black light source for fluorescent penetrant inspection is determined by measuring the intensity of the black light at a distance of 15 inches from the front or out-side surface of the black light source filter. This intensity SHALL be at least 1000 micro-watts/cm.sq. and sources providing less than this intensity shall not be utilized. New bulbs can vary by as much as 50 percent in their initial output. This means that with two new bulbs, one may have an intensity that is double that of the other without either being defective. New black light bulbs SHALL be tested with an ultraviolet light meter for output before being used.

e. Ambient Light Restriction. The ambient light levels within the inspection station of the fluorescent penetrant inspection unit SHALL NOT exceed 2 lumens per square foot. When performing portable fluorescent penetrant inspection, a dark canvas or photographer's black cloth SHALL be used to darken the inspection area of interest to the lowest possible ambient light level during the inspection.

f. Black Light Hazards.

(1) Black light bulbs SHALL NOT be operated without filters. Cracked, chipped, or ill-fitting filters SHALL be replaced before using the lamp. High intensity "super" black lights that use bulbs with integral filters SHALL have a splash guard attached to the front of the lamp housing to prevent accidental implosion of the bulb. This splash guard SHALL be the manufactured item.

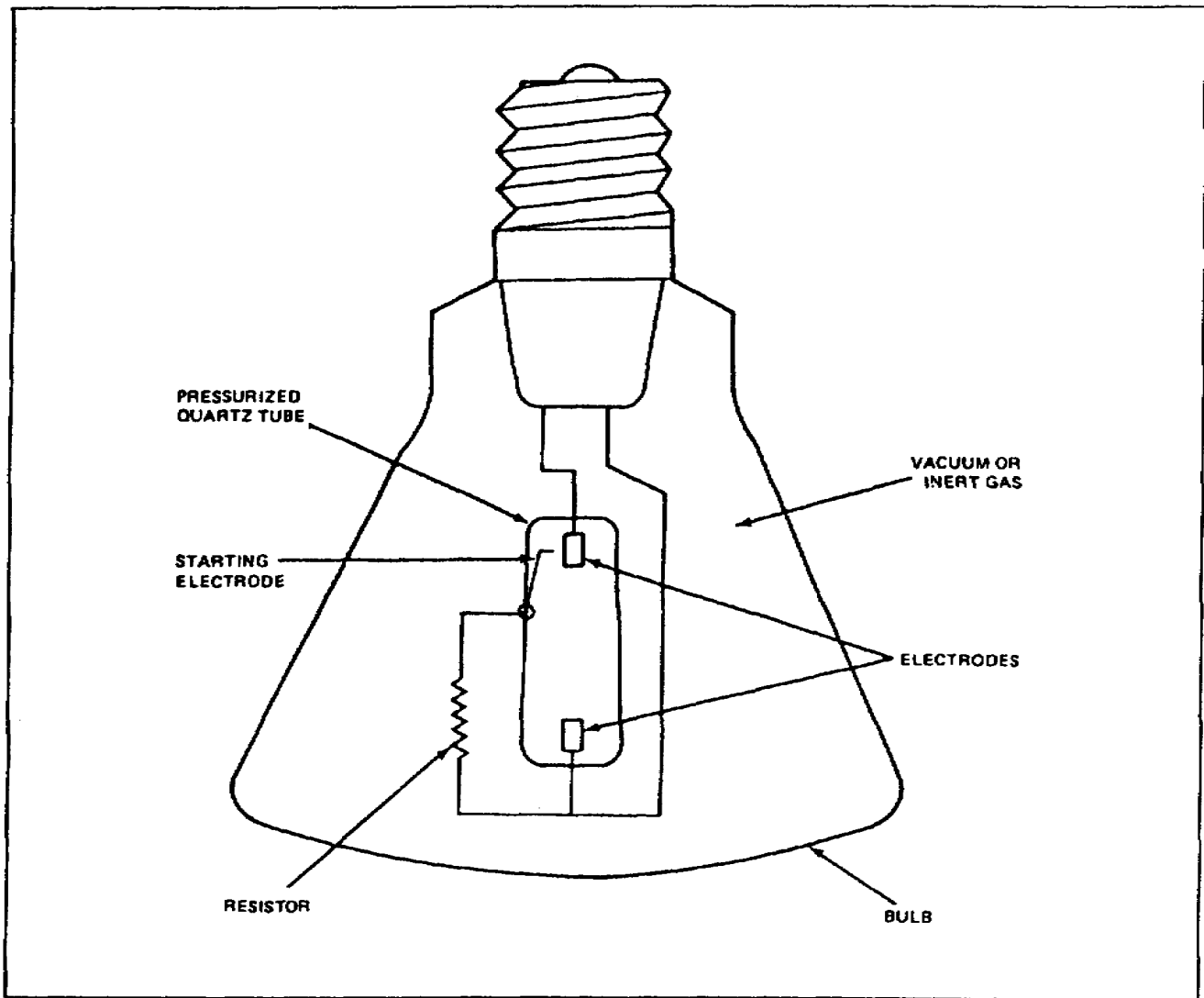

Figure 1-11. High-pressure mercury-vapor bulb

(2) Prolonged direct exposure of hands to the filtered black light main beam may be harmful. White cotton glove liners or other suitable gloves shall be worn when exposing hands to the main beam.

(3) The temperature of some operating black light bulbs reaches 750 Fahrenheit or more during operation. This is above the ignition or flash point of fuel vapors. These vapors will burst into flame if they contact the bulb. These black lights **SHALL NOT** be operated when flammable vapors are present.

(4) The bulb temperature also heats the external surfaces of the lamp housing. The temperature is not high enough to be visually apparent but is high enough to cause severe burns with even momentary contact of exposed body surfaces. Extreme care must be exercised to prevent contacting the housing with any part of the body.

g. Dark Adaptation. The human eye becomes many times more sensitive to light under dark conditions. This increased sensitivity gradually occurs when light conditions change from light to dark. When first entering a dark area from a lighted area, little or nothing can be seen. The pupil of the eye must widen to admit more light, and the mechanism of vision slowly changes. Full sensitivity or dark adaptation requires about 20 minutes. A dark adaptation time of 5 minutes is usually sufficient for penetrant inspection with black light. An inspector entering a darkened area SHALL allow at least 5 minutes for dark adaptation before examining parts. Sun glasses and glasses with photochromatic lens that darken when exposed to sunlight SHALL NOT be worn when performing fluorescent penetrant inspection.

h. Cleanliness. The inspection area, hands, and clothing of the inspector SHALL be clean and free of extraneous penetrant materials. Nonrelevant indications may be formed when parts contact extraneous penetrant materials. In addition, the fluorescent from the penetrant will raise the ambient light level, thus reducing sensitivity.

### 30. Inspection, Interpretation, and Evaluation.

a. Interpretation. Interpretation is the process of detecting an indication and the process of determining whether an indication is relevant, nonrelevant, or false.

b. Relevant. A relevant indication is one resulting from a discontinuity, while a nonrelevant indication is not associated with a parts structural condition or discontinuity.

c. Nonrelevant. Nonrelevant indication can result from an intentional change in part shape such as threads or small radii. The concern over nonrelevant indications is whether they mask or cover a true discontinuity indication.

d. Service-Induced Discontinuities. The most frequently encountered service discontinuities detected by penetrant inspection are fatigue cracks. Stress corrosion and overload cracking are also common. Overload fractures occur when the stress exceeds the tensile strength of the part. This is greater than the yield point and the fracture is accompanied by some

distortion. Cracks caused by the overloading are relatively large and are further magnified by the distortion, making them easy to detect visually without penetrant inspection.

e. Evaluation of Indications. Indications can be indistinct and blurred while still being highly visible. The following method may be used to verify and evaluate the type of indication. Carefully wipe the indication area once with a fast drying solvent such as 1,1,1 trichloroethane, naphtha, xylene, methylene chloride, or clean degreasing fluid. After the solvent has evaporated, spray a very light layer of solvent developer over the area and watch the indication as it begins and continues to develop. If it does not reappear, wipe again with solvent and examine the bare surface with a 3X to 5X magnifying glass. Evaluation of penetrant indications with a magnifying glass should be accomplished with the developer removed. Developer will blur and enlarge the indication. The initial evaluation should be done at low magnification (3X to 5X) with higher magnification (10X) used only after the indication has been located. If no penetrant bleed-out or surface imperfection can be seen, the original indication could have been nonrelevant and due to improper processing.

**THIS PAGE INTENTIONALLY LEFT BLANK**

## LESSON 1

### PRACTICE EXERCISE

The following items will test your grasp of the material covered in this lesson. There is only one correct answer for each item. When you complete the exercise, check your answer with the answer key that follows. If you answer any item incorrectly, study again that part of the lesson which contains the portion involved.

1. Which is an advantage of liquid penetrant inspection?
  - A. Able to detect subsurface defects.
  - B. Can be used on most porous materials.
  - C. Able to examine complex shapes in one operation.
  - D. Able to detect surface defects.
  
2. Which type and method of penetrant may be used on aircraft parts?
  - A. Type I, Method A.
  - B. Type I, Method D.
  - C. Type II, Method A.
  - D. Type II, Method C.
  
3. Penetrant materials are compounded or formulated for specific
  - A. aircraft parts.
  - B. forms of developer.
  - C. area or location.
  - D. removal methods.
  
4. The operating range for conventional penetrants is
  - A. 40°-100° Fahrenheit.
  - B. 40°-120° Fahrenheit.
  - C. 60°-100° Fahrenheit.
  - D. 60°-120° Fahrenheit.

**THIS PAGE INTENTIONALLY LEFT BLANK**

5. Nonaqueous wet developers are always applied by
- A. dipping.
  - B. pouring.
  - C. spraying.
  - D. brushing.
6. Which service discontinuities detected are most frequently encountered using penetrant inspection?
- A. Fatigue cracks.
  - B. Stress corrosion cracking.
  - C. Overload cracking.
  - D. Thermal cracks.

## LESSON 1

### PRACTICE EXERCISE

#### ANSWER KEY AND FEEDBACK

<u>Item</u>	<u>Correct Answer and Feedback</u>
1.	<p>C. Able to examine complex shapes in one operation.</p> <p>Liquid penetrant is capable of examining all of the exterior surfaces of objects, even of complex shapes, in one operation. (page 1-4, para 6[a])</p>
2.	<p>B. Type I, Method D.</p> <p>This is the only type authorized for use on aircraft. (page 1-7, para 8[a])</p> <p>Water-washable penetrants, Method A, SHALL NOT be used on aircraft and engine parts. (page 1-8, para 9[a])</p>
3.	<p>D. Removal methods.</p> <p>Penetrant materials are compounded or formulated for specific removal methods. (page 1-8, para 9)</p>
4.	<p>B. 40°-120° Fahrenheit.</p> <p>The operating range for conventional penetrants is 40°-120° Fahrenheit (part temperature). (page 1-14, para 18)</p>
5.	<p>C. Spraying.</p> <p>Nonaqueous wet developers are always applied by spraying. (page 1-23, para 28c[4])</p>
6.	<p>A. Fatigue cracks.</p> <p>The most frequently encountered service discontinuities detected by penetrant inspection are fatigue cracks. (page 1-26, para 30[d])</p>

## LESSON 2

### MAGNETIC PARTICLE TESTING

#### OVERVIEW

##### LESSON DESCRIPTION:

In this lesson you will be introduced to the fundamentals of magnetic particle inspection.

##### TERMINAL LEARNING OBJECTIVE:

**ACTION:** Develop a knowledge of the fundamentals of magnetic particle inspection.

**CONDITIONS:** You will be given the instructions in this lesson covering magnetic particle inspection.

**STANDARD:** You will demonstrate a knowledge of the material presented in this lesson by correctly completing the practical exercise.

**REFERENCES:** The material contained in this lesson was derived from TM 55-1500-335-23 and MIL-STD-1949.

#### INTRODUCTION

Discontinuities may exist in raw materials, be formed during processing of fabrication of parts, or exist as fatigue cracks or cracks due to excessive service stresses. Discontinuities are considered defects if their existence is detrimental or harmful to the usefulness of the parts. Magnetic particle inspection can readily and reliably locate discontinuities in ferromagnetic material to reveal manufacturing and/or service induced defects.

1. Purpose. Magnetic particle inspection is a nondestructive method for revealing surface, and near subsurface, discontinuities in parts made of magnetic materials. It consists of three basic operations--

- a. Establishment of a suitable magnetic field.
- b. Application of magnetic particles.
- c. Examination and evaluation of particle accumulations.

2. Capabilities of Magnetic Particle Inspection. Magnetic particle inspection can detect discontinuities in parts made of magnetic materials. If the part is made from an alloy which contains a high percentage of iron and the part can be magnetized, it is in a class of metals called "ferromagnetic" and can be inspected by this method. If the part is made of material which is nonmagnetic, it cannot be inspected by this method. The magnetic particle inspection method will detect surface discontinuities including those that are too fine to be seen with the naked eye; those that lie slightly below the surface; and, when special equipment is used, the more deeply seated discontinuities.

3. Basic Terminology. To discuss the magnetic particle inspection process, certain terms and essential principles of magnetism must be defined and understood. The following definitions are provided to best suit the purpose of this lesson.

a. Ferromagnetic Materials. The attraction or repulsion of most metals when under the influence of a magnet is very slight. A few metals, particularly iron, steel, cobalt, and nickel, are strongly attracted. These materials, permeable to magnetic flux, are called ferromagnetic. In magnetic particle testing, we are concerned only with ferromagnetic materials.

b. Leakage Field. This is a magnetic field forced out into the air by the distortion of the field within a part caused by the presence of a discontinuity or change in section configuration.

c. Magnetic Flux. Magnetism may be considered a force which tends to produce a magnetic field. Magnetic flux is a condition in this magnetic field which accounts for the effect of the field on magnetic materials.

d. Permeability. The ease with which a metal or metallic part can be magnetized is called permeability. A metal that is easy to magnetize is said to have high permeability or to be highly permeable. A metal that is difficult to magnetize is said

to have low permeability. Soft iron and iron with a low percentage of carbon are usually easy to magnetize and are highly permeable. Hard steel with a high percentage of carbon content is usually hard to magnetize and, therefore, is usually lower in permeability. Permeability and retentivity are inversely related characteristics.- The higher the permeability, the lower the retentivity.

e. Residual Magnetism. The magnetic field that remains in the parts when the magnetizing force has been reduced to zero or the magnetizing current is shut off is called the residual field. The magnetism which remains is called residual magnetism.

f. Retentivity. The property of any magnetic metal to keep or retain a magnetic field after the magnetizing current is removed is called retentivity.

4. Electricity and Magnetism. Electricity can be used to create or induce magnetic fields in parts made of magnetic materials. Magnetic lines of force are always aligned at right angles (90°) to the direction of electric current flow. Since it is possible to control the direction of the magnetic field by controlling the direction of the magnetizing current, it is important to know how to use electricity to induce the magnetic lines of force so that they intercept and are as near as possible to right angles to the defect or discontinuity.

5. Magnetic Attraction. The concept of flux lines includes flow, distribution, directional, and attraction-repulsion properties. Each flux line is considered to be a continuous loop, which is never broken but must complete itself through some path. The flux lines always leave a magnet at right angles to the surface. They always seek the path of lowest reluctance (opposition to the establishment of magnetic flux) in completing their loop. When a piece of soft iron is placed in a magnetic field, it will be drawn toward the magnetic source. This is the action which causes magnetic particles to concentrate at leakage fields at discontinuities. Since the magnetic particles offer a lower reluctance path to the flux lines, they are therefore drawn to the discontinuity and bridge the air gap (Figure 2-1).

6. Effects of Flux Direction. The magnetic field must be in a favorable direction to produce indications. When the flux lines are oriented in a direction parallel to a discontinuity, the indication will be weak or lacking. The best results are obtained when the flux lines are in a direction at right angles

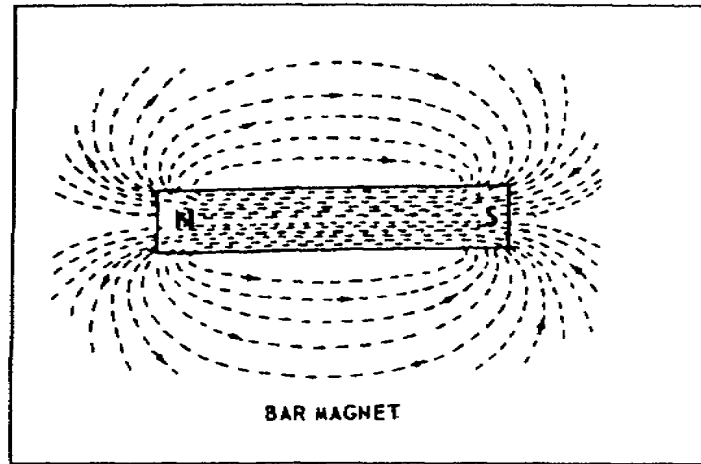

Figure 2-1. Magnetic flux lines

to the discontinuity. If a discontinuity is to produce a leakage field and a readable magnetic particle indication, the discontinuity must intercept the flux lines of force at some angle. When an electrical magnetizing current is used, the best indications are produced when the path of the magnetizing current is flowing parallel to the discontinuity because the magnetic flux lines are always at an angle of 90 to the flow of magnetizing current (Figure 2-2).

7. Circular Magnetization. Circular magnetization derives its name from the fact that a circular magnetic field always surrounds a conductor such as a wire or a bar carrying an electric current. The direction of the magnetic lines of force is always at right angles to the direction of the magnetizing current. An easy way to remember the direction of magnetic lines of force around a conductor is to imagine that you are grasping the conductor with your hand so that the extended thumb points parallel to the electric current flow. The fingers then point in the direction of the magnetic lines of force. Conversely, if the fingers point in the direction of current flow, the extended thumb points in the direction of the magnetic lines of force (Figure 2-3).

a. Circular Magnetic Field in Part. To create or induce a circular field in a part with stationary magnetic particle inspection equipment, the part is clamped between the contact plates, and current is passed through the part. This sets up a circular magnetic field in the part which creates poles on either side of any crack or discontinuity which runs parallel to the length of the part. The poles will attract magnetic particles, forming an indication of the discontinuity (Figure 2-4).

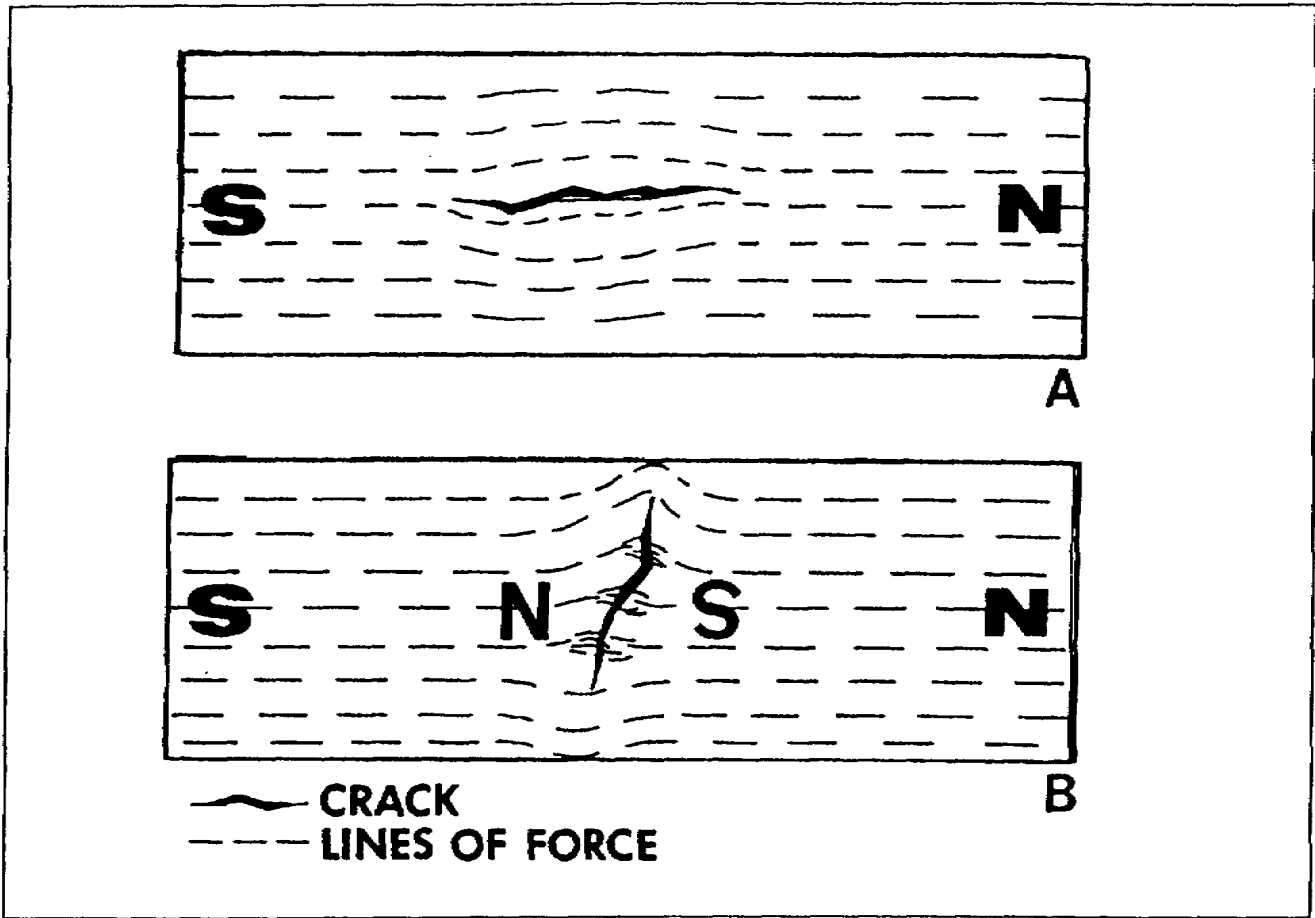

Figure 2-2. Effects of flux direction

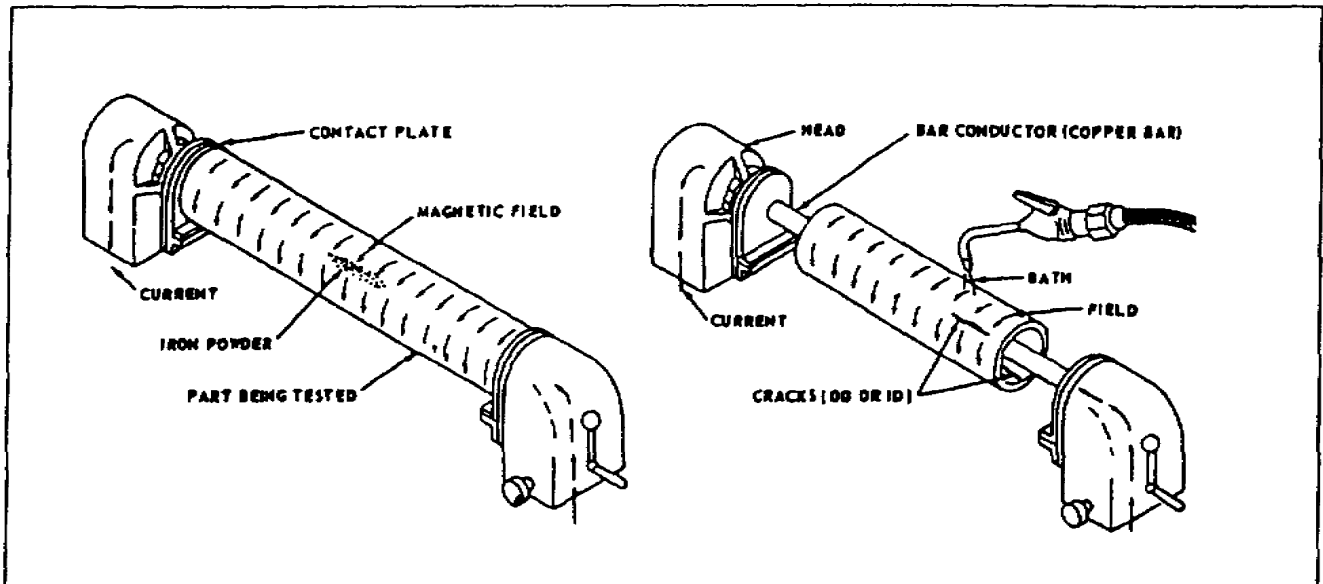

Figure 2-3. Circular magnetization

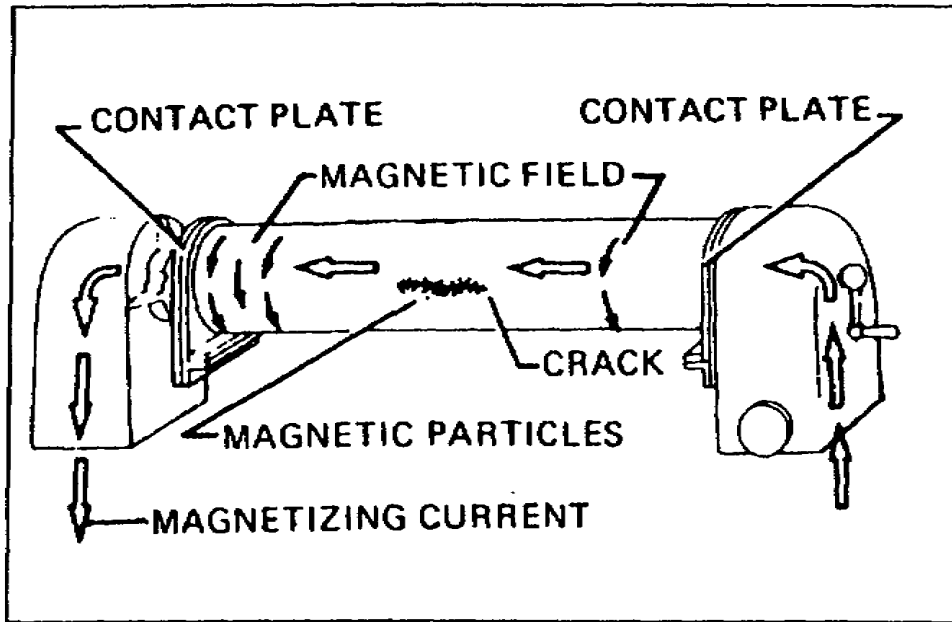

Figure 2-4. Circular magnetic field in a part

b. **Circular Magnetization Using a Central Conductor.** On parts that are hollow or tubelike, the inside surfaces are as important to inspect as the outside. When such parts are circularly magnetized by passing the magnetizing current through the part, the magnetic field on the inside surface is negligible. Since there is a magnetic field surrounding the conductor of an electric current, it is possible to induce a satisfactory magnetic field by placing the part on a copper bar or other conductor. Passing current through the bar induces a magnetic field on both the inside and outside of the part. When using a central bar conductor, alternating current is only to be used when inspecting for surface discontinuities on the inside circumference of the part (Figure 2-5).

8. **Longitudinal Magnetization.** When a part made of magnetic material is placed inside a coil, the magnetic lines of force created by the magnetizing current concentrate themselves in the part and induce a longitudinal magnetic field. If there is a transverse discontinuity in the part, small magnetic poles are formed on either side of the crack. These poles will attract magnetic particles, forming an indication of the discontinuity. Compare Figure 2-4 and Figure 2-6 and note that in both cases a magnetic field has been induced in the part which is at right angles to the defect. This is the most desirable condition for reliable inspection (Figure 2-6).

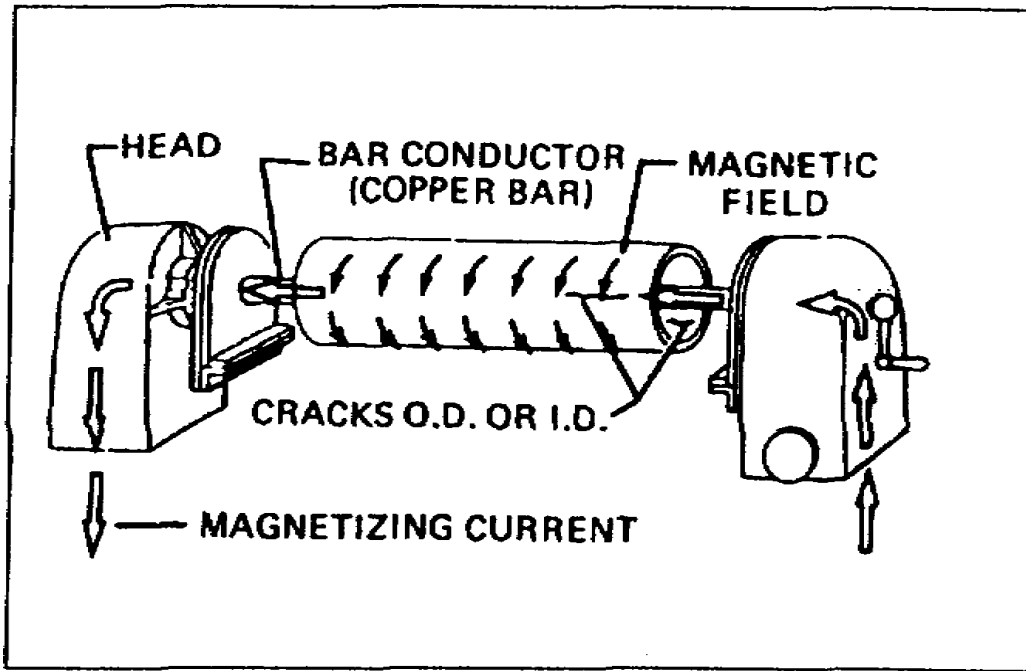

Figure 2-5. Circular magnetization using a central conductor

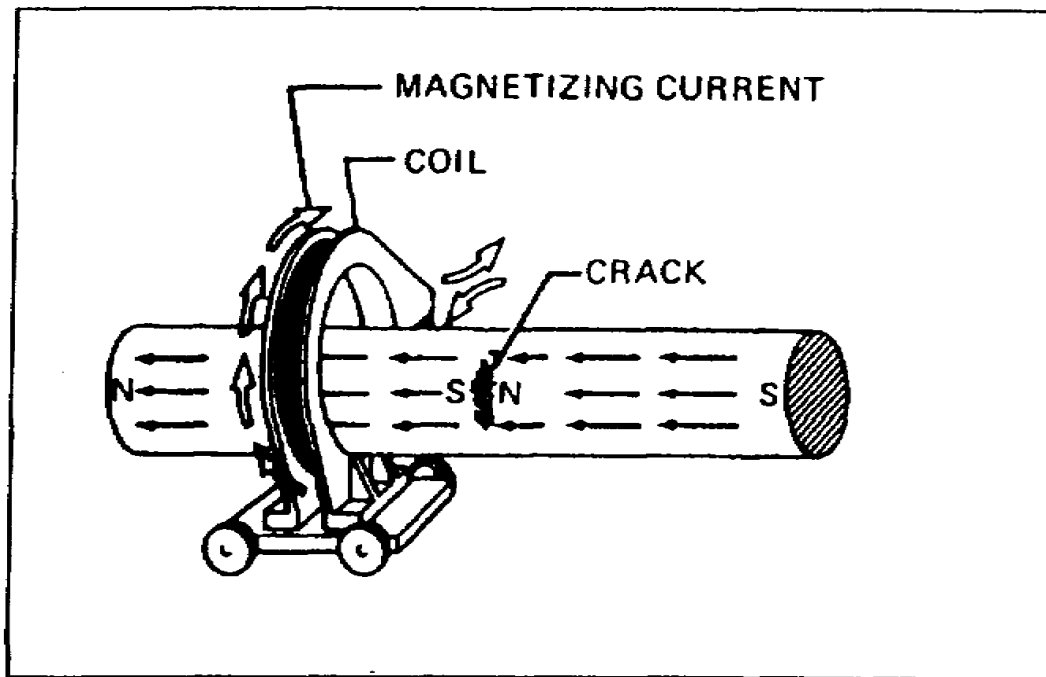

Figure 2-6. Longitudinal magnetization

9. Magnetizing Equipment. Considerations involved in the selection of magnetic particle inspection equipment include the type of magnetizing current and the location and nature of inspection.

a. Stationary Equipment. Stationary equipment primarily uses AC. These units are located at fixed base units (Figure 2-7).

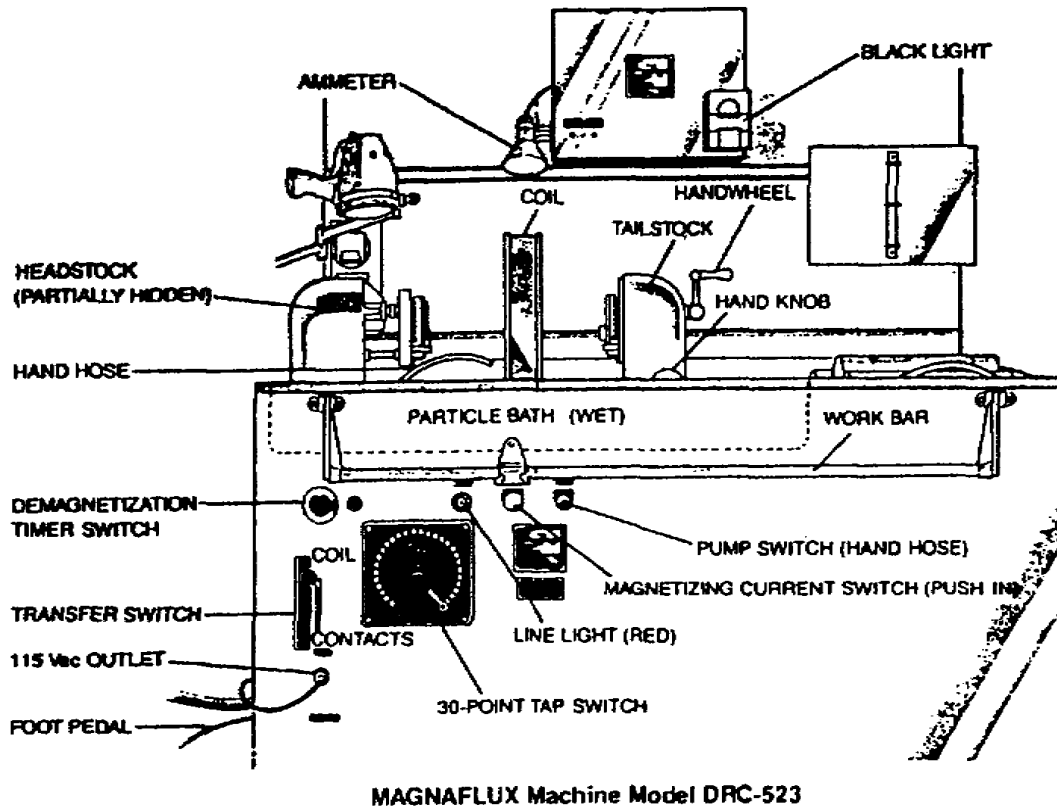

Figure 2-7. Stationary equipment

b. Portable Equipment. Basically, portable equipment operates on the same principle as stationary equipment. It is suitable for examining small areas in large components where suspected cracks may be found. Most portable equipment can be moved to the aircraft and inspection performed without removal of components.

(1) Electromagnetic Probe Yoke. Electromagnetic probe yokes are U-shaped cores of soft iron with a coil wound around the base of the U. When alternating current or rectified alternating current is passing through the coil, the two ends of the core are magnetized with opposite polarity. The combination is an electromagnetic probe yoke, similar to a permanent horseshoe magnet. A probe yoke may be used to induce only a LONGITUDINAL FIELD in a part. No electrical current passes through the part. Electromagnetic probe yokes are located at the nondivisional and divisional AVIM shop sets (Figure 2-8).

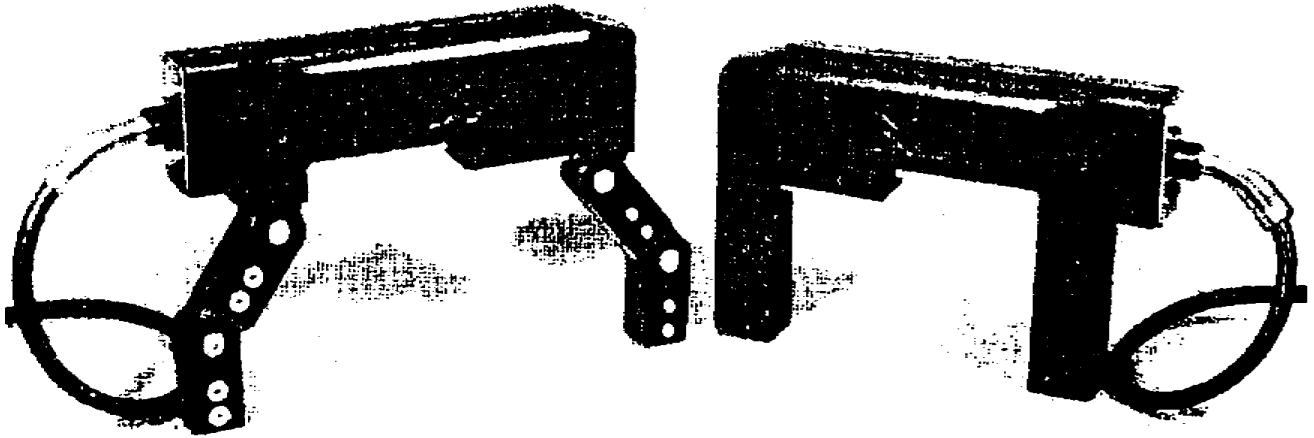

Figure 2-8. Electromagnetic probe yoke

(2) Hand Held Coil. The hand held coil is used for longitudinal magnetization of shafts, spindles, rear axles, and similar small parts. Note that the magnetic field produced is the same as the electromagnetic probe yoke (Figure 2-9).

10. Preinspection Cleaning. Parts or surfaces should be clean and dry before they are subjected to any magnetic particle inspection process. The cleaning process used must not affect the part in any way that will reduce the effectiveness of the inspection process. The cleaning process is required to remove all contaminants, foreign matter, and debris that might interfere with the application of current or the deposit of the magnetic particles on the test surface.

a. Cleaning Process Residues. Residues from cleaning processes can remain on the part surface and become contaminants. Paint removers can leave sticky residues which either trap particles or contaminate recirculating baths.



Figure 2-9. Hand held coil

Alkaline cleaner residues can loosen the binder holding fluorescent dye to the magnetic particles. All cleaning residues must be removed before inspecting parts or components. Moisture from cleaning processes and liquids from vapor degreasers or solvent cleaners are also contaminants. All parts must be clean and dry before the inspection process takes place.

b. Painted or Plated Surfaces. Paint or plating on the surface of a part has the effect of making a surface defect behave like a subsurface defect. If fine cracks are suspected, the surface should be stripped of the coating if its thickness exceeds 0.005 inch. Most coatings of cadmium, nickel, or chromium are usually thinner than this, and the plating makes an excellent background for viewing indications.

c. Service Contaminates. Dirt, rust, loose scale, or paint and oil, or grease should be removed. The part should be free of oil contaminates that can dissolve into the inspection bath which will substantially reduce its effective life. Insoluble particle contaminants on the surface such as rust, sand, or grit do not lower inspection sensitivity. They can, however, accumulate in a recirculating wet bath to the point where they can hide the contrast of indications and force the bath to be discarded sooner than normal.

11. Post-Inspection Cleaning. The magnetic particle inspection process leaves behind at least a scattering of magnetic particles which are abrasive. This may or may not be harmful to the later reuse of the part subjected to the inspection process. Where this slight residue cannot be tolerated, it must be removed. In the event that a functional material such as oil, grease, or antiseize compound is removed from the part to facilitate inspection, the same material shall be reapplied after the part has been inspected.

12. Selection of Amperage. The application of any rule-of-thumb amperage figure is fairly straightforward in the case of uniform cylindrically shaped parts. On parts having complicated shapes such as irregular forging, machinery parts, weldments, or castings, the use of any rule-of-thumb amperage figure is not practical. In these cases the operator must rely on judgement and past experience to aid him in the selection of the optimum amperage. Experience with similar parts which do have discontinuities is especially helpful in this respect. Too low an amperage may produce leakage fields too weak to form readily discernible indications. Too high an amperage creates a heavy background accumulation of particles which may mask an indication. In circular magnetization, too high an amperage may burn current contact points of a part.

a. Circular Magnetization. Circular magnetization is used for the detection of radial discontinuities around edges of holes or openings in parts. It is also used for the detection of longitudinal discontinuities which lie in the same direction as the current flow, either in a part or in a part which a central conductor passes through.

(1) Direct Contact. Generally, the diameter of the part shall be taken as the largest distance between any two points on the outside circumference of the part. In highly permeable material, lower amperage per inch of diameter will produce an adequate field strength within the part. Normally, currents will be 500 amperes per inch of part diameter.

(2) Central Conductor. Keep in mind that the magnetizing field strength around a central conductor decreases with distance away from the conductor with the strongest flux field being present at the surface inside the central conductor's hole. When using a central bar conductor, alternating current is only to be used when inspecting for surface discontinuities on the inside circumference of the part. Normally currents will be 1000 amperes per inch of wall thickness. If only the inside surface is to be inspected, the diameter shall be the largest distance between two points, 180 degrees apart, on the inside circumference. The central bar conductor should have an outside

diameter as close as practically possible to the inside diameter of the hole of the part that is being inspected. Use the following formula to determine the number of times the part must be rotated, in equal degrees, and remagnetized/reinspected to ensure a complete inspection has been performed.

$$S = \frac{D_p \pi}{4 (.9 D_c)}$$

**Where:**

**Dp = diameter of hole**

**Dc = diameter of central bar  
conductor**

**$\pi$  = 3.1416**

**S = number of remagnetizations**

b. Longitudinal Magnetization. Longitudinal magnetization is used for the detection of circumferential discontinuities which lie in a direction transverse to, or at approximately right angles to, a part's axis. Circumferential discontinuities around a cylinder, for example, are detected by magnetizing the cylinder longitudinally in a direction parallel with its axis. A portion of the longitudinal field will cross the discontinuities creating leakage fields which can capture and hold magnetic particles to form indications at the discontinuities.

(1) Effective Magnetizing Field. The effective magnetizing field produced by a coil extends approximately 6 to 9 inches on either side of the coil center. For parts longer than the effective field distance, more than one inspection along the entire length will be required. When repositioning these longer parts in the coil, allow a 3 inch effective field overlap. A part that is 18 inches long would not be repositioned in coil, whereas a part that is 30 inches long would be positioned at 15-inch intervals in the coil.

(2) L/D Ratio. To find the length to diameter ratio, measure the part's length and divide by the part's largest diameter. This ratio of the part should be greater than 3, but less than 15 for the rule-of-thumb formulas to be accurate. Coil amperages become impractically large for L/D ratios of 3 or less. Small ratios of 3 or less can be effectively increased by using pole pieces of magnetic material. The pole pieces must be made from laminated magnetic material similar to the silicon steel legs of a hand probe with articulated legs. All three pieces must be lined up in the direction of the applied field or coil's axis. Very long parts having L/D ratios greater than 15

should receive multiple inspections along the length of a part. The most effective field in a part extends about 6 to 9 inches on each side of a coil.

(3) Cross-Sectional Area. It is critical to determine the relationship between the cross-sectional area of the part and the cross-sectional area of the coil. This relationship/ratio will determine whether the part can be inspected within a coil of a given diameter by lying the part in the bottom or next to the side of the coil wall or by centering the part in the coil and which formula will be used for estimating the amperage required. The cross-sectional area for the part and coil are determined using the formula  $A = R^2$ , where:

$$\begin{aligned} \mathbf{A} &= \mathbf{Cross-sectional\ area} \\ \mathbf{\pi} &= \mathbf{3.14} \\ \mathbf{R} &= \mathbf{Radius\ (1/2\ of\ the\ diameter)} \end{aligned}$$

(a) When the cross-sectional area of the part is less than one tenth the cross-sectional area of the coil, the part should be magnetized lying in the bottom of the coil.

(b) When the cross-sectional area of the part is greater than one tenth the cross-sectional area of the coil, the part must be magnetized in the center of the coil.

(c) When using a cable wrap or when the cross-sectional area of the part exceeds one half the cross-sectional area of the coil, the part should be centered in the coil. The formula for high-fill factor coils SHALL be used for estimating the required amperage.

(4) Formula for Part Lying in Bottom of Coil. This formula should be used when the cross-sectional area of the part is less than one tenth the cross-sectional area of the coil. This formula SHALL be used whenever the part is lying in the bottom of the coil or is placed next to the coil wall during magnetization. If the part has hollow portions, replace D with D<sub>eff</sub> (see subparagraph 7).

$$\mathbf{I} = \frac{\mathbf{KD\ (\pm 10\%)}}{\mathbf{NL}}$$

**Where:** **I = Amperes required through coil**  
**K = 45,000 ampere turns (constant)**  
**L = Length of the part**  
**D = Diameter of the part (measured in same units as length)**  
**N = Number of turns in the coil**

(5) Formula for Part in Center of Coil. This formula SHALL be used when the cross-sectional area of part is greater than one tenth and less than one half the cross-sectional area of the coil.

$$I = \frac{KR}{N \left( \frac{6L}{D} \right)^{-5}} (\pm 10\%)$$

**Where:** I = Amperes through the coil  
 K = 43,000 ampere turns (constant)  
 R = Radius of coil in inches  
 N = Number of coil turns  
 L = Length of the part  
 D = Diameter of the part (measured in same units as length)

(6) Formula for Cable Wrap or High-Fill Factor Coil. This formula SHALL be used when the cross-sectional area of the part is greater than one half the cross-sectional area of the coil. The part should be placed in the center of the coil.

$$I = \frac{K}{N \left( \frac{L + 2}{D} \right)} (\pm 10\%)$$

**Where:**  
 K = 35,000 (constant)  
 N = Number of coil or cable turns  
 L = Length of the part  
 D = Diameter of the part (measured in same units as length)

(7) Formula for the Effective Diameter (DEFF). If the part is hollow or has hollow portions, replace the diameter (D) with the effective diameter (DEFF).

$$DEFF = \sqrt{OD^2 - ID^2}$$

**Where:**  
 OD<sup>2</sup> = Largest outside diameter of the part times itself  
 ID<sup>2</sup> = Smallest inside diameter of the part times itself  
 √ = Square root

### 13. Inspection Media Materials.

a. Magnetic Particles. There are two basic classes of magnetic particles available for use. The wet method particles use a liquid vehicle; the dry method particles are borne by air. Either water or oil may be used as a liquid vehicle for the wet method. The wet particles are best suited for the detection of fine surface cracks such as fatigue cracks. For field applications, aerosol cans of magnetic wet bath are employed.

(1) Dry Powder Method. The dry powder method is primarily used for the inspection of welds and castings where the detection of defects lying wholly below the surface is considered important. Dry powder method shall not be used on aircraft or turbine engine parts without specific approval of the appropriate engineering authority for the individual inspection requirements.

(2) Wet Visible Method. This is available as a reddish brown or black powder in an oil or water bath. The wet visible method shall not be used on aircraft or turbine engine parts without specific approval of the appropriate engineering authority for the individual inspection requirements.

(3) Wet Fluorescent Method. The fluorescent particle method is faster, more reliable, and more sensitive to very fine defects than the visible colored particle method in most applications. Indications are easier to detect, especially in high-volume testing. In addition, the fluorescent method has all the other advantages possessed by the wet visible suspension technique. Wet fluorescent method is the only method authorized for use on aircraft.

#### b. Suspension Characteristics.

(1) Oil Suspension. The oil should have very definite properties to be suitable for bath purposes. It should be a well-refined, light petroleum distillate of low viscosity, odorless, with a low sulphur content, with a high flash point, and a fairly high, narrow boiling range.

(2) Water Suspension. Water is initially cheaper, but additions shall be made before it is a suitable medium for suspending the wet magnetic particles. Wetting agents, anti-foaming materials, corrosion inhibitors, suspending and dispersing agents are all necessary and must be carefully controlled. In order to assure proper control of the water conditioners, water as a suspending liquid shall not be used unless water chemistry services are available. Use of water baths is prohibited on cadmium-plated steels with tensile strength above 180 KSI.

(3) Bath Concentration. The optimum range for most magnetic particle bath concentrations is 0.15 to 0.20 ml/100 ml for fluorescent particles. The bath strength for oil bath suspensions should be checked daily prior to use and after every 8 hours of continuous operation. A 100 ml centrifuge tube is used for this test (Figure 2-10).

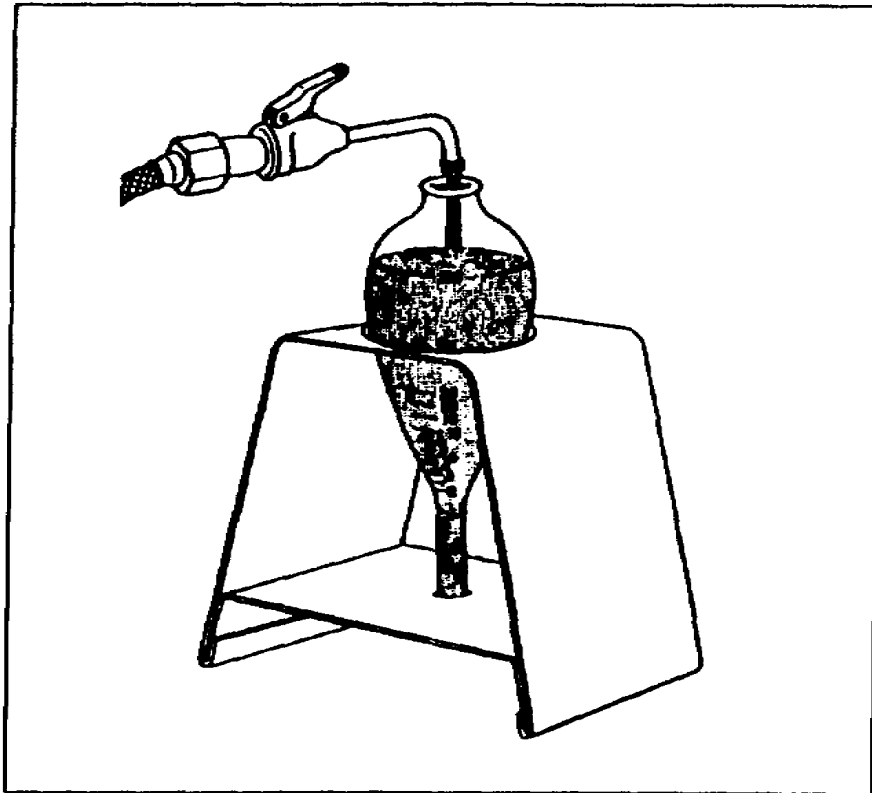

Figure 2-10. Centrifuge tube

14. Lighting and Facilities. The requirements are the same for magnetic particle inspections as the liquid penetrant inspections (See page 1-23, paragraph 29).

15. Demagnetization. Parts fabricated from ferromagnetic material retain a certain amount of residual magnetism (or remanent field) after application of a magnetizing form. This does not affect the mechanical properties of the part. However, it is necessary to reduce the residual magnetism retained in a part by demagnetization. Ferromagnetic air frame parts are demagnetized to prevent magnetic flux from affecting instrumentation.

a. Demagnetization Process. Demagnetization is the process of removing the magnetic field from a part. This is done by passing the part through a coil with electric current flowing through it. Do not get this confused with longitudinal magnetism as they are not the same. There are two methods of doing this, one using alternating current, and the other using direct current. In theory a bar of iron or other metal is made up of a number of small particles with their own permanent magnetic fields. In the bar of iron that is unmagnetized, the particles are arranged in random fashion so the magnetic fields of the particles tend to cancel out each other. In the magnetizing process, the particles are arranged in the same direction by another magnet. But in the demagnetization process that uses alternating current, the induced magnetic field continually reverses itself as the part is placed in the coil and then drawn away slowly, or slowly reduce the current. As the current is reversing, the magnetic particles inside the metal are being scrambled. When the part is drawn away, or when current flow reaches zero, the part is no longer magnetized (Figure 2-11).

b. Field Indicator. When a field indicator is placed in a magnetic field, it indicates the strength of that portion of the magnetic field which passes through the sensing element of the indicator. The indicator gives an indication of magnetizing force of the leakage field passing through its sensing element rather than the flux density in the part from which the leakage field emanates. Field indicators being used in support of magnetic particle inspections SHALL be kept away from the influence of magnetizing or demagnetizing magnetic flux (Figure 2-12).

## 16. Interpretation and Evaluation.

a. Indication. In magnetic particle inspection an indication is an accumulation of magnetic particles being held by a magnetic leakage field to the surface of a part. The indication may be caused by a discontinuity (an actual void or break in the metal), or it may be caused by some other condition that produces a leakage field.

### b. Basic Steps of Inspection.

- (1) Producing an indication on a part.
- (2) Interpreting the indication.
- (3) Evaluating the indication.

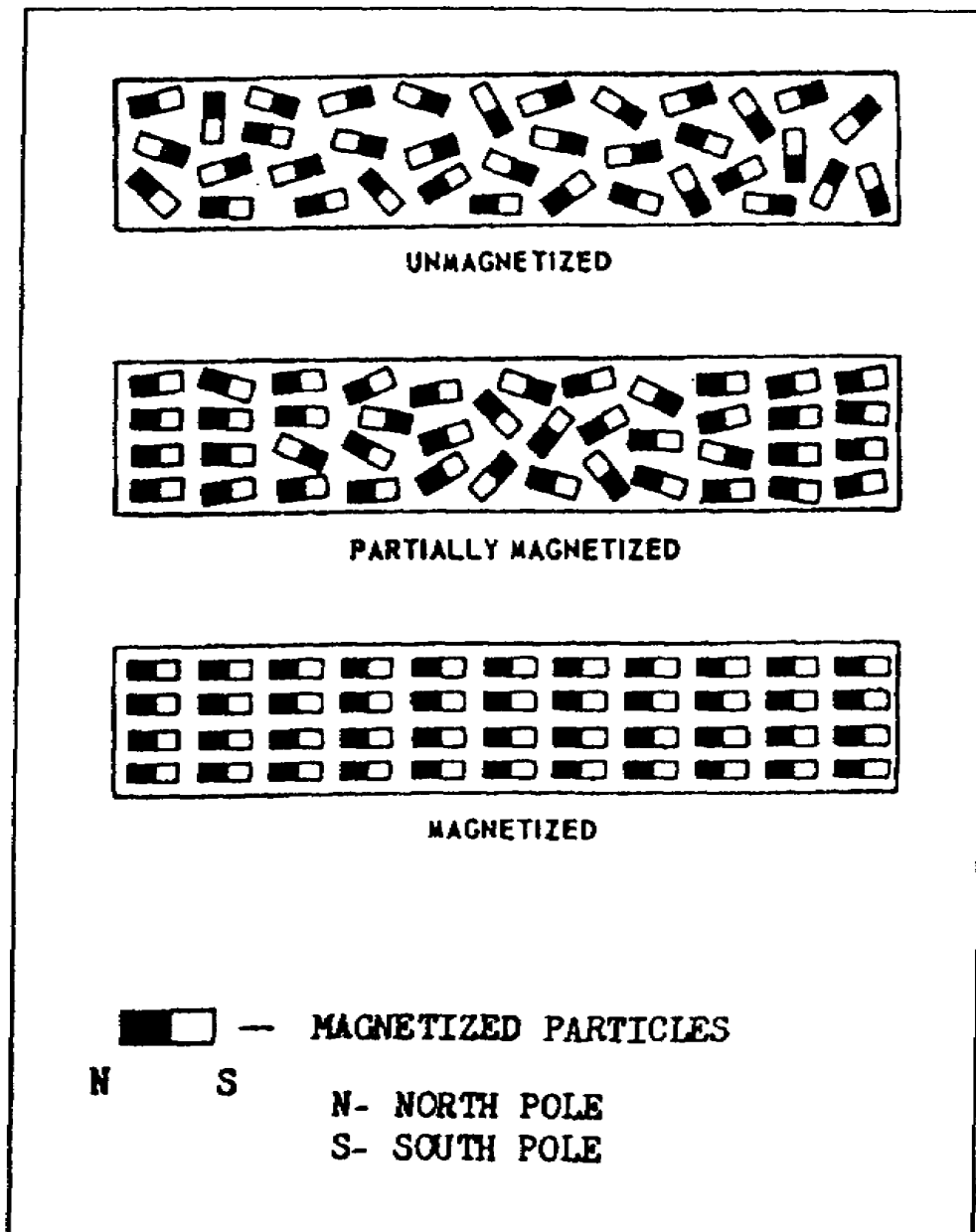

Figure 2-11. Demagnetization process

c. Interpreting the Indication. After the indication is created, it is necessary to interpret that indication. Interpretation is the deciding of what caused that indication, what magnetic disturbance has attracted the particles in the particular pattern found on the part. If the operator knows something about metal processing, it is possible to determine from the appearance and location of an indication the cause of the indication.

d. Nonrelevant Indications. It is possible to magnetize parts of certain shapes in such a way that magnetic leakage fields are even though there is no discontinuity in the metal at

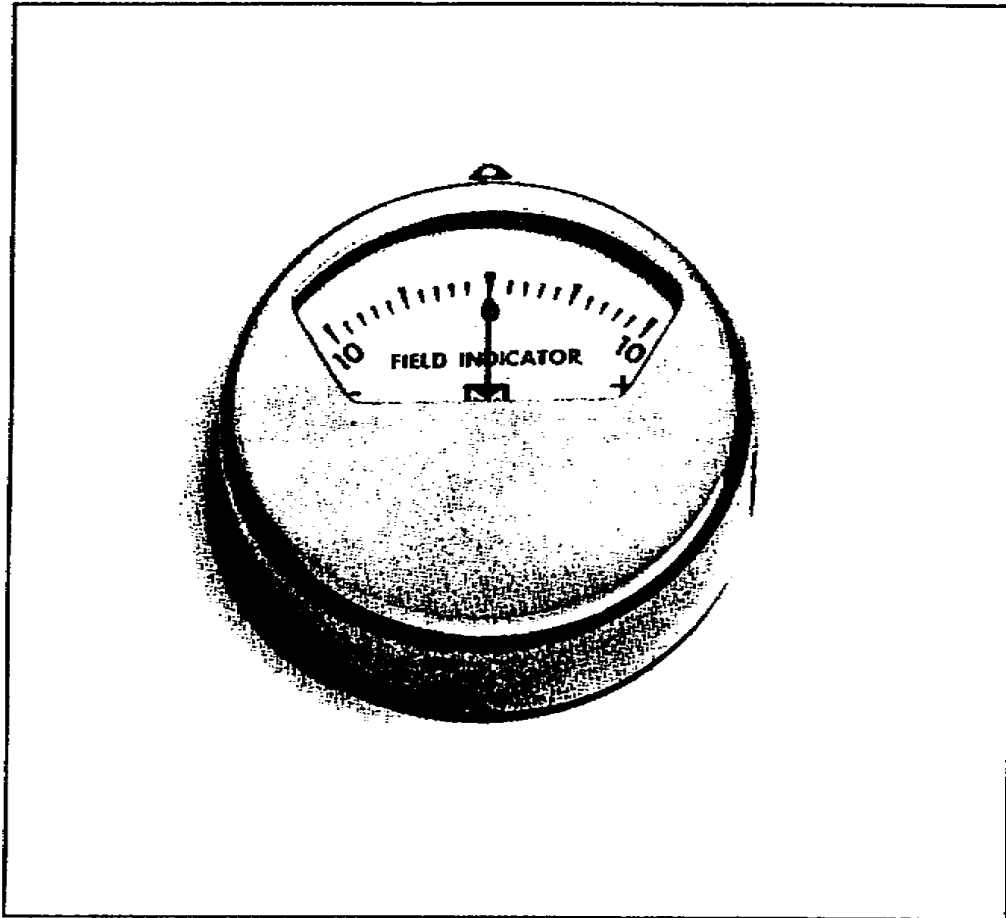

Figure 2-12. Field indicator

part of the metal at that point. Such indications are sometimes called erroneous indications or false indications. They should be called "nonrelevant indications" since they are actually caused by distortion of the magnetic field. They are real indications; but, since there is no interruption in the metal, they do not affect the usefulness of the part. It is important that the operator know how and why these nonrelevant indications are formed and where to look for them on the parts being inspected.

e. Elimination of Nonrelevant Indications. Although nonrelevant indications can be recognized in most cases, they do not tend to increase the inspection time and, under certain conditions, may mask or cover up indications of actual defects. Therefore it is desirable to eliminate them whenever possible. In most cases nonrelevant indications occur when the magnetizing current is higher than necessary for a given part. The proper procedure is to demagnetize and reinspect using a lower value of magnetizing current. Care must be taken not to reduce the current below the value required to produce indications of all

actual discontinuities. Where there are abrupt changes of section, two inspections may be required: one at a fairly low amperage to only inspect the areas at the change in section, the other at a higher current value to inspect the remainder of the part.

## LESSON 2

### PRACTICE EXERCISE

The following items will test your grasp of the material covered in this lesson. There is only one correct answer for each item. When you complete the exercise, check your answer with the answer key that follows. If you answer any item incorrectly, study again that part of the lesson which contains the portion involved.

1. Which magnetic field is produced by the electromagnetic probe yoke?
  - A. Circular.
  - B. Longitudinal.
  - C. Parallel.
  - D. Multidirectional.
  
2. What direction is the magnetic lines of force in relation to the electric current flow?
  - A. Parallel to the length of the part.
  - B. Rapid alternation of field direction.
  - C. In the same direction.
  - D. At an angle of 90°.
  
3. Which type of current is best suited for detecting surface discontinuities on the inside circumference of a part?
  - A. Alternating.
  - B. Direct.
  - C. Halfwave.
  - D. Rectified.
  
4. What must be done to a painted part, if the coating does not exceed 0.0005 inch, prior to a magnetic particle inspection?
  - A. Acid dipped.
  - B. Cleaned and dried.
  - C. Paint removed.
  - D. Sand blasted.

**THIS PAGE INTENTIONALLY LEFT BLANK**

5. What is the effective magnetizing field on either side of the coil center?
- A. 3 to 6 inches.
  - B. 3 to 9 inches.
  - C. 6 to 9 inches.
  - D. 15 to 18 inches.
6. Which magnetic particle method is the only method authorized for use on aircraft?
- A. Dry powder.
  - B. Wet visible.
  - C. Oil suspension.
  - D. Wet fluorescent.

## LESSON 2

### PRACTICE EXERCISE

#### ANSWER KEY AND FEEDBACK

<u>Item</u>	<u>Correct Answer and Feedback</u>
1.	<p>B. Longitudinal.</p> <p>A probe yoke maybe used to induce only a longitudinal field in a part. (page 2-8, para 9b[1])</p>
2.	<p>D. At an angle of 90°.</p> <p>The magnetic flux lines are always at an angle of 900 to the flow of the magnetizing current. (page 2-4, para 6)</p>
3.	<p>A. Alternating.</p> <p>When using a central bar conductor, alternating current is only to be used when inspecting for surface discontinuities on the inside circumference of the part. (page 2-6, para 7b)</p>
4.	<p>B. Cleaned and dried.</p> <p>All parts must be clean and dry before the inspection process takes place. Painted or plated surfaces do not have to be stripped if the coating does not exceed 0.005 inch. (page 2-9, para 10a)</p>
5.	<p>C. 6 to 9 inches.</p> <p>The effective magnetizing field produced by a coil extends approximately 6 to 9 inches on either side of the coil center. (page 2-12, para 12b11])</p>
6.	<p>D. Wet fluorescent.</p> <p>Wet fluorescent method is the only method authorized for use on aircraft. (page 2-15, para 13a[3])</p>

## APPENDIX A

### REFERENCES

MIL-STD-410	Nondestructive Testing Personnel Qualification and Certification, July 1974
MIL-STD-1949	Inspection, Magnetic Particle, July 1987
MIL-STD-6866	Inspection, Liquid Penetrant, November 1985
TM55-1500-335-23	Nondestructive Inspection Methods, March 1990

**THIS PAGE INTENTIONALLY LEFT BLANK**

## APPENDIX B

### GLOSSARY

**ABSORPTION:** The process of one material merging with a second material by penetration into the particles of the second material...as opposed to adsorption where the material coats and is retained on the surface of the particles of the second material.

**ADSORPTION:** The process of one material merging with a second material by coating and being retained on the surface of the particles of the second material...as opposed to absorption where the material penetrates into the particles of the second material.

**ALTERNATING CURRENT:** Alternating current is current that reverses its direction of flow at regular intervals. Such current is frequently referred to as AC.

**AMPERAGE:** The strength of a current of electricity measured in amperes.

**AMPERE:** This is the unit of electrical current. One ampere is the current which flows through a conductor having a resistance of one ohm, at a potential of one volt.

**BACKGROUND:** The surface of the test part upon which the indication is viewed. It may be the natural surface of the test part, or it may be the developer coating on the surface. This background may contain traces of unremoved penetrant, fluorescent or visible which, if present, can interfere with the visibility of the indication.

**BACKGROUND FLUORESCENCE:** Fluorescent residues observed over the general surface of the part during fluorescent penetrant inspection. It is usually due to poor emulsification or rinsing of the fluorescent penetrant or due to excessive roughness of the surface causing entrapment of the fluorescent penetrant.

**BATH:**

- (1) The liquid penetrant inspection materials (penetrant, emulsifier, developer) into which parts are immersed during the inspection process.
- (2) Penetrant materials retained in bulk in immersion tanks intended for reuse.
- (3) Term used to designate a suspension of ferromagnetic particles with oil or water.

**BLACK LIGHT:** The term given to electromagnetic radiation having wavelengths between 2000 and 4000 angstrom units. Typical units used in penetrant inspection provide an intensity of 100 to 150 footcandles at 15 inches from the face of the filter and are used to excite fluorescent materials in a range visible to the eye.

**BLACK LIGHT INTENSITY:** The amount of properly filtered black light measured at the surface of the part being inspected.

**BLACK LIGHT FILTER:** A filter that transmits ultraviolet light (3200 to 4000 Å wavelength) while suppressing the transmission of visible light of the longer wavelengths.

**BLEED OUT:** The action by which the penetrant exudes out of the discontinuities onto the surface of a component, due primarily to "capillary action" and to "blotting" or "soaking up" effect of the developer.

**CENTRAL CONDUCTOR:** A conductor made of copper, aluminum, steel, or flexible cable that is passed into or through an opening in a cylindrically-shaped part or other shapes when applicable for the purpose of establishing a circular field on the inside diameter.

**COIL:** One or more turns of conductor wound to produce a magnetic field when current passes through the conductor.

**COIL SHOT:** A term used colloquially to indicate a shot of magnetizing current passed through a solenoid or coil surrounding a part, for the purpose of establishing a longitudinal field.

**CONTINUOUS METHOD:** The method in which the inspection medium is applied just prior to turning the magnetizing current on.

**CRACKS, FATIGUE:** Progressive cracks which develop in the surface caused by the repeated loading and unloading of the part, or by what is called reverse bending.

**DEMAGNETIZATION:** The reduction in the degree of residual magnetism in ferromagnetic materials to an acceptable level.

**DEVELOPER:** Material, wet or dry, which will draw or absorb penetrant from a surface crack or defect to the extent the defect will be visible under natural, artificial, or black light, as applicable. Developers also control the background of the high-contrast penetrant color system.

**DEVELOPING TIME:** The elapsed time necessary for the applied developer to bring out indications from penetrant entrapments. Usually one-half the penetrant dwell time.

**DISCONTINUITY:** An interruption in the normal physical structure or configuration of a part such as cracks, laps, seams, inclusions, porosity. A discontinuity may or may not affect the usefulness of a part.

**DRYING OVEN:** An oven used for drying rinse water from test pieces.

**DWELL TIME:** The period of time wherein the liquid penetrant remains on the surface of the part.

**EMULSIFICATION:** The process of dispersing one liquid in a second immiscible liquid; the largest group of emulsifying agents are soaps, detergents, and other compounds, whose basic structure is a paraffin chain terminating in a polar group.

**EMULSIFIER:** A liquid agent which must be applied to the nonwater-washable penetrant after the proper dwell time has elapsed to permit water rinsing. This requires an additional step, and a period of time must be allowed for the combining to occur. A suspension of one liquid phase in another.

**EMULSIFIER-REMOVER:** A type of solvent that can be rinsed off with water after it is applied or used as a solvent wipe remover.

**EMULSIFICATION TIME:** Time required for the emulsifying agent to combine with the penetrant. This is critical as insufficient time will result in failure to remove the penetrant and lead to false indications, and too long a time may remove the penetrant from the flaws. Emulsification time usually ranges from 30 seconds to 5 minutes.

**FIELD, CIRCULAR:** The magnetic field surrounding any magnetic conductor or part resulting from the current being passed through a central conductor or the part.

**FIELD, LEAKAGE:** The field which leaves or enters the surface of a part at a discontinuity or change in section configuration.

**FIELD, LONGITUDINAL:** A field created by a coil shot or cable wrap and in which the flux lines traverse the part essentially parallel with its longitudinal axis. A localized field, on the surface of a part, traversing from one leg of a yoke or probe to the other.

**FIELD, MAGNETIC:** The space within and surrounding a magnetized part or a conductor carrying current in which magnetic lines of force exist.

**FIELD, RESIDUAL:** The magnetism that remains in a piece of magnetizable material after the magnetizing force has been removed.

**HEADSHOT:** A term used colloquially to designate the magnetizing current passing through a part or a central conductor while clamped between the head contacts of a stationary magnetizing unit for the purpose of circular magnetization.

**HORSESHOE MAGNET:** A bar magnet, bent into the shape of a horseshoe so that the two poles are adjacent. Usually the term applies to a permanent magnet.

**HYDROPHILIC:** Having an affinity for, attracting, adsorbing, or absorbing water. A substance soluble in water.

**INDICATION:** In nondestructive inspection, a response or evidence of a response that requires interpretation to determine its significance.

**INSPECTION:** Process of examining for possible defects or for deviation from established standards.

**INTERPRETATION:** The determination of the cause of an indication or the evaluation of the significance of discontinuities from the standpoint of whether they are detrimental defects or superficial blemishes.

**LENGTH/DIAMETER RATIO:** A ratio of the length and diameter of a part for the purpose of calculating the amperage required for longitudinal magnetization.

**LIGHT METER:** A device used to measure the light in footcandles or microwatts per square centimeter, whichever is appropriate.

**LIPOPHILIC:** Relating to or having strong affinity for fats or other liquids. Promoting the solubilization or absorption of liquids. An oil- or fat-based substance.

**LIQUID VEHICLE:** The liquid in which the magnetic particles are suspended to facilitate their application.

**LONGITUDINAL MAGNETIZATION:** Magnetization of material in such a way that the magnetic lines of force are essentially parallel to the axis of the magnetizing coil or to a line connecting the two poles when a yoke or probe is used.

**LUMEN:** A unit of luminous flux equal to the light emitted in a unit solid angle by uniform point source of one candle.

**MAGNET:** Materials that show the power to attract iron and other substances to themselves, and that exhibit polarity, are called magnets.

**MAGNETIC DISCONTINUITY:** This refers to a break in the magnetic uniformity of the part, a sudden change in permeability. A magnetic discontinuity may not be related to any actual physical break in the metal, but it may produce a magnetic particle indication.

**MAGNETIC FIELD:** The space around a source of magnetic flux in which the effects of magnetization can be determined.

**MAGNETIC FIELD STRENGTH:** The intensity of the magnetic field surrounding the magnetized part measured in GAUSS.

**MAGNETIC FLUX:** The total number of magnetic lines existing in a magnetic circuit.

**MAGNETIC FORCE:** In magnetic particle inspection the magnetization force is considered to be the total force tending to set up a flux in a magnetic circuit. It is usually designated by the letter "H."

**MAGNETIC MATERIALS:** Materials are affected by magnets in two general ways. Some of them are attracted by a magnetic force, while others exert a repellent force. The first is called "paramagnetic" and the latter "diamagnetic." In magnetic particle inspection we are not ordinarily concerned with either of the two classes but with what may be termed a subdivision of the first class called "ferromagnetic materials."

**MAGNET PARTICLE INSPECTION:** A method for detecting discontinuities on or near the surface in suitably magnetized materials, which employ finely divided magnetic particles that tend to concentrate in regions of the magnetic nonuniformity, i.e., along cracks, over inclusions, voids, etc.

**MAGNETIC PERMEABILITY:** A term indicating the ease with which a magnetic field can be established in a material. It is determined by the ratio of the resultant magnetic force to the applied magnetic force.

**MAGNETIC POLES:** The ability of a magnet to attract or repel is not uniform over its surface, but it is concentrated at local areas called "poles." Each magnet has at least two poles, one of which is attracted by the earth' s North Pole and is called the north pole of the magnet; the other is attracted by the earth' s South Pole and is called the south pole of the magnet.

**MAGNETIC WRITING:** A form of nonregulation indications, sometimes caused when the surface of a magnetized part comes into contact with another piece of ferromagnetic material.

**MAGNETISM:** The ability of matter to attract other matter to itself and exhibit polarity.

**MAGNETIZING CURRENT:** The flow of either alternating, rectified A<sup>0</sup>, or direct current used to induce magnetism into the part.

**MAGNETIZING FORCE:** For the purpose of this discussion, magnetizing force is considered to be the total force tending to set up magnetic flux in a magnetic circuit. It is usually designated by the letter "H" and the unit is "oersted."

**MOBILITY:** The ease with which magnetic particles move over the surface of a magnetized part and accumulate at a discontinuity exhibiting polarity.

**(MT) SYMBOL:** Symbol for the magnetic particle method of nondestructive testing/inspection.

**NONDESTRUCTIVE INSPECTION:** A method used to check the soundness of a material or a part without impairing or destroying the serviceability of the part.

**NONFERROMAGNETIC MATERIAL:** A material that is not magnetizable and, hence, essentially not affected by magnetic fields. This would include paramagnetic materials having a magnetic permeability slightly greater than that of a vacuum and approximately independent of the magnetizing force and diamagnetic materials having a permeability less than a vacuum. Metals free from iron, such as zinc, tin, aluminum, brass, copper, and pot metal.

**NONRELEVANT INDICATIONS:** An indication due to misapplied or improper inspection. Also, an indication caused by an actual discontinuity in the material which does not affect the usefulness of the part (such as a change of section).

**PENETRANT:** A liquid of high surface tension and capillary action which is a vehicle for colored or a fluorescent dye used to penetrate into the defect and detect surface discontinuities.

**PENETRANT INDICATION:** Readings which mark or denote the presence of a material defect.

**PENETRANT, POST-EMULSIFIABLE:** A penetrant that requires the application of a separate emulsifier to render the surface penetrant water-washable.

**PENETRANT REMOVER:** A penetrant remover is a solvent-type liquid used to clean penetrants from the surface of a material.

**PENETRANT SENSITIVITY:** Penetrant remover is the ability of the penetrant, processing technique, and developer to detect surface-connected discontinuities and provide an indication visible to the unaided eye.

**PERMEABILITY:** The ease with which a material can become magnetized. It is the relationship between field strength and the magnetizing force.

**POLARITY:** The quality of having two opposite magnetic poles, one north and one south.

**POLE:** The area on a magnetized part from which the magnetic field leaves or enters the part.

**POROSITY:** Random pits or holes in the surface of the object caused by gases being liberated as the material solidifies.

**POST-CLEANING:** The removal of residual penetrant and/or developer from the item after the inspection operation.

**POST-EMULSIFICATION:** The technique wherein a separate emulsifying step is required to facilitate water rinse removal of the surface penetrant.

**RESIDUAL MAGNETISM:** The magnetic field remaining in a part after the current has been removed.

**RESIDUAL METHOD:** Bath is applied after current has been shut off; that is, the indicating particles are on the part when residual magnetic field is present.

**RESIDUAL METHOD:** The method in which magnetic particles are applied to the material after the magnetizing current has been discontinued.

**RETENTIVITY:** The ability of a material to retain magnetism after the current has been removed.

**SEAM:** A discontinuity caused by a void or crack in rolled material parallel to the axis of the material which, although closed, is not welded. A line of junction; a line, groove, ridge, or interstice formed by or between two contracting edges.

**SOLUBLE:** The amount of a substance that will dissolve in a given amount of another substance and is typically expressed as the number of parts by weight dissolved by 100 parts of solvent at a specified temperature and pressure or as a percent by weight or by volume.

**STRESS-CORROSION CRACKING:** Failure by cracking under combined action of corrosion and stress, either external (applied) or internal (residual). Cracking may be either intergranular or transgranular, depending on metal and corrosive medium.

**SUBSURFACE DEFECT:** Any defect which does not break the surface of the part in which it exists.

**VISCOSITY:** A measurement of a liquid' s resistance to change of shape or flow. Also referred to as flow resistance.

**WET CONTINUOUS PROCESS:** The method of applying the wet suspension to the inspection surfaces just prior to applying the magnetizing current.

**YOKE:** A C-shaped piece of soft magnetic material, either solid or laminated, around which is wound a coil carrying the magnetizing current.

## EXAMINATION

### Materials needed to take the examination:

Subcourse booklet, number 2 lead pencil, and ACCP examination response sheet.

### Instructions:

There is only one correct answer for each item. Mark the correct answer for each item, then transfer your answers to the ACCP examination response sheet, completely blacking out the lettered oval which corresponds to your selection (A, B, C, or D). Use a number 2 lead pencil to mark your responses. Mail your response sheet in the preaddressed envelope you received with this subcourse.

1. Which is a disadvantage of liquid penetrant inspection?
  - A. Unable to detect smaller discontinuities than most other NDI methods.
  - B. Unable to magnify the indication.
  - C. Unable to examine complex shapes in one operation.
  - D. Unable to detect subsurface defects.
  
2. Which type of penetrant CAN be used on aircraft parts?
  - A. I.
  - B. II.
  - C. III.
  - D. IV.
  
3. Under the "system concepts," which component combinations must be supplied by the same manufacturer as a system?
  - A. Penetrant and developer.
  - B. Developer and remover.
  - C. Penetrant and emulsifier.
  - D. Cleaner and developer.
  
4. Penetrant inspections are reliable only when the parts to be inspected are
  - A. made from nonferrous materials.
  - B. free of contaminates.
  - C. simple in shape.
  - D. cleaned by vapor degreasing.

5. Penetrant dwell time for stress corrosion will not be
  - A. less than 30 minutes.
  - B. more than 30 minutes.
  - C. less than 240 minutes.
  - D. more than 240 minutes.
  
6. If, during a Method B penetrant inspection, the dwell time allowed for the emulsifier is suspected of being too short, then
  - A. the emulsifier shall be reapplied.
  - B. the developer dwell time shall be shortened proportionally.
  - C. the part shall be reprocessed starting with penetrant application.
  - D. the part shall be completely reprocessed starting with precleaning.
  
7. What is the maximum emulsifier dwell time when performing a Method B penetrant inspection?
  - A. 10 seconds.
  - B. 30 seconds.
  - C. 1 minute.
  - D. 5 minutes.
  
8. Which of the following steps SHALL NOT be accomplished when removing the excess penetrant from a part being processed using Method C?
  - A. Saturate the cloth with spray-on solvent.
  - B. Examine the part surface under a black light during final wiping stages.
  - C. Examine the rag surface under a black light after the final solvent wipe.
  - D. Repeat the process until the rag shows little or no trace of penetrant.
  
9. Which developer CANNOT be used on aircraft or engine parts?
  - A. Dry powder.
  - B. Water suspended.
  - C. Water soluble.
  - D. Solvent suspended.
  
10. Which form of developer provides the highest sensitivity?
  - A. Dry powder.
  - B. Water soluble.
  - C. Water suspended.
  - D. Nonaqueous.

11. What is the minimum developer dwell time that can be used when performing a penetrant inspection?
- A. At least one fourth of the penetrant dwell time.
  - B. At least one third of the penetrant dwell time.
  - C. At least one half of the penetrant dwell time.
  - D. At least one fifth of the penetrant dwell time.
12. What is the required black light intensity at 15 inches?
- A. Not more than 2 lumens per square foot.
  - B. 320 to 400 nanometers.
  - C. At least 1000 microwatts per square centimeter.
  - D. 3000 microwatts per square centimeter.
13. The direction of the magnetic field can be altered and is controlled by
- A. the direction of the magnetizing current.
  - B. the strength of the magnetizing current.
  - C. the size of the central conductor.
  - D. the permeability of the part.
14. Which magnetic field is produced by the hand held coil?
- A. Circular.
  - B. Longitudinal.
  - C. Parallel.
  - D. Multidirectional.
15. Which factor should be considered when determining what current amperage to use for the circular magnetization of a part?
- A. The part' s length through which the current will flow.
  - B. The amount of heating that can be tolerated at the current contact areas.
  - C. The number of discontinuities expected to be found on the part.
  - D. The position of the part within the coil.
16. What is circular magnetization used for?
- A. Detection of longitudinal discontinuities.
  - B. Detection of circumferential discontinuities.
  - C. Detection of circular cracks around a cylinder.
  - D. Detection of subsurface circular cracks.

17. What is called for when the length to diameter (L/D) ratio of a part is less than three?
- A. Impractically large amperages.
  - B. Multiple magnetizations.
  - C. Part centered in the coil.
  - D. Longitudinal magnetization.
18. The effective magnetic field produced on each side of the coil only extends a maximum of
- A. 3 inches.
  - B. 9 inches.
  - C. 12 inches.
  - D. 15 inches.
19. Which magnetic particle method is faster, more reliable, and more sensitive to very fine cracks?
- A. Black powder.
  - B. Dry powder.
  - C. Wet fluorescent.
  - D. Wet visible.
20. On wet fluorescent magnetic particle machines, the oil bath strength should be checked daily prior to use and during every
- A. 2 hours of operation.
  - B. 4 hours of operation.
  - C. 6 hours of operation.
  - D. 8 hours of operation.